

WE ARE ENVIRONMENTALLY-FRIENDLY

Recycling means to repeat the life cycle continuously ,by giving new use to materials discarded by society. We are increasingly concerned about using recyclable and environmentally-friendly raw materials.

The recyclable materials used in our manufacturing processes come from plastic, cotton, artificial wood and glass fiber reinforced materials. The recyclable materials of our products consist of wood from self-sustainable forests, fabric, ceramics and chipboards.

Our painting method uses ecological paints with environmentally harmless dyes and components and no active solvents. Recycling offers an indeterminate number of advantages. It prevents soil and water contamination, reduces the volume of waste that goes to the sanitary landfills, also generates jobs for many people and saves natural resources.

In the course of the years, **SonicHive** Acoustic Panels has become increasingly concerned about and aware of the need to reduce inert matters that pollute the planet. This is an issue that concerns all of us and the industrial world must pay careful attention in particular.

[Http://www.thesonichive.com](http://www.thesonichive.com)

Easy acoustic system

sonichive

Product Catalogue

Easy acoustic system



Scan Website

Sonic Hive Trading,
Ground Floor, Al Wasl Building, Next to Dubai Mall/ Burj Khalifa Metro Station,
Exit 2, Sheikh Zayed Road, Dubai, United Arab Emirates.



Ph: +971 58 555 00 99 | Email: info@thesonichive.com
www.thesonichive.com

2023/10

NO ACOUSTIC NO DECOR NO

We fulfill the acoustic environment by creative ways, complying strict acoustic standards and manufacturing technique from products design and production to solutions putting forward.
 We fulfill acoustic requirements from AV room, instruments playing, studio recording, office meeting room, classroom, catering & entertainment, commercial & household easily.
 We renovate uncertainty of meeting acoustic standards and quality defects from traditional decoration. Our solutions cater to the pickiest ears.
 We suit for all types of interior decoration, easy to install on ceilings or walls. With the help of computer calculation and acoustic analysis, the acoustic product has been continuously developed and improved.
 The features and actual application of the product are optimized based on the test data, making the product further improved toward perfection.
 The product is a combination of artistic appearance, quality, high efficiency and personalized design.
 The product can meet high end requirements. We are **SonicHive** an extraordinary example in the acoustic world.



01

EQ
EQ Walleasear

EQ30/60/120T W-absorber
 EQ50R Rococo
 EQ50B Baroque
 EQ50Q Versailles
 EQ2 Mirage
 EQ3 Phantom
 EQ4 Cobble
 EQ5 Geometric



19

Imagine
Imagine Acoustic Panel

Imagine
Imagine Acoustic Panel
 Imagine
Imagine Acoustic Magic



35

QRD
QRD Two-dimensional Diffusion Easeapps

D64 Chessfuser
 D30/30S Quadrifuser
 N8 Octofuser
 N29 Metafuser
 D80 Fuseaser
 D80W Trapfuser
 D60 Trifuser
 D60W Trapfuser



17

EQ
Basstrap

EQ101A/B
Cylinder Basstrap
 EQ102A/B
Corner Basstrap



27

AQ
AQ Intelligent Modularity Easeapps

AQ1000S Acoustic Baffle
 AQ1000SL Haydn Acoustic Array
 AQ1000SW Bach Acoustic Array
 AQ1000M Smartfuser
 AQ1000H/HD Movable Acoustic Baffle
 AQ150W Movable Acoustic Baffle



44

MLS
MLS Three-dimensional Diffusion Easeapps

PEAK 5Q iffuser
 CLOUD 2C Diffuser
 ARC 300W Basstrap
 ARC 300 Diffuser
 WAVE 600 Diffuser
 PEAK 2000D&A/D Diffuser
 PYRAMID 4Q Diffuser





Name: W-absorber
Model: EQ30 EQ60 EQ120 (Angle T / Chamfer TD)
Base Material: 100% eco-friendly acoustic composite fiber wool
Finish: SF-series, UA-series, YC-series, XY-series fabric acoustic cloth surface finishing
Eco-Friendly: Zero Formaldehyde emission; Enf standard
Specification: Refer to standard specifications (non-standard customized quantity $\geq 10m^2$)
Weight: EQ30 $\leq 4.8kg/m^2$, EQ60 $\leq 7.0kg/m^2$, EQ120 $\leq 13.0kg/m^2$

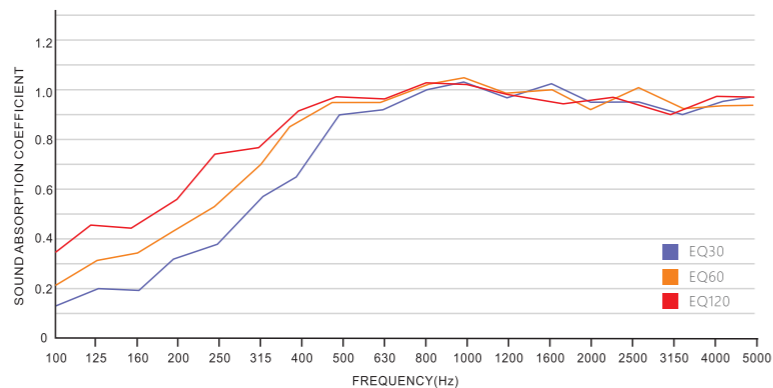

- Since our product is designed in modular form, we can configure it different combinations and able to strike a balance between space aesthetics and acoustic.
- Walleasear able to absorbs sound in all frequency, being able to form either a diffusing wall or low frequency trap easily.
- To control main reflections in strong energy by forming a broadband frequency absorbing wall
- Its double bandwidth suits with broadband frequency sound absorber and to accompany a surface in the ratio of 1 (Absorption):1(Diffusion)
- For broadband frequency acoustic treatment in different spaces
- In unbalanced spaces, it helps to set up a balanced absorbing surface via customizing into different sizes.
- This is the perfect acoustic treatment for you to control the sound with easily installed system and will not influence the natural sound atmosphere you preferred.

Depending on your application, we can arrange the panel in different arrays, e.g. studios, halls, small conference rooms, entertainment rooms and classrooms. Panels are usually flush mounted in different cluster, so that energy will not be reflected repetitively. In this way, they help to control sound waves by maximizing the absorption efficiency. Soundbox® 'Walleasear' is designed to be a combination on large wall surfaces with random spacing, called second diffusion panel after soft diffusion. In the space between the reflection panel, some energy is absorbed, while others is reflected back the space. Under this path, controlling fluttering echo and standing waves are much better. At the same time, we reserve the sense of space in those rooms. SonicHive 'Walleasear', an easily installed solution and able to preserve a natural acoustic ambience. The best choice for solving ceaseless echoes in home theaters, SonicHive 'Walleasear', save your cost in reverberation time controlling for small spaces, such as studios, instrument practicing rooms and HIFI rooms, etc.

Model

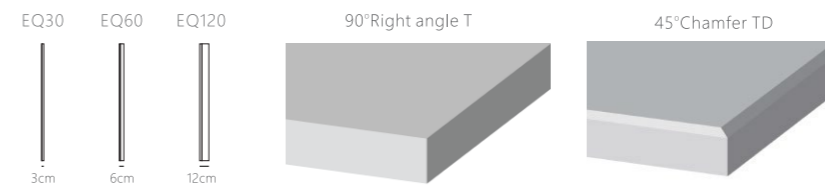

Installation diagram

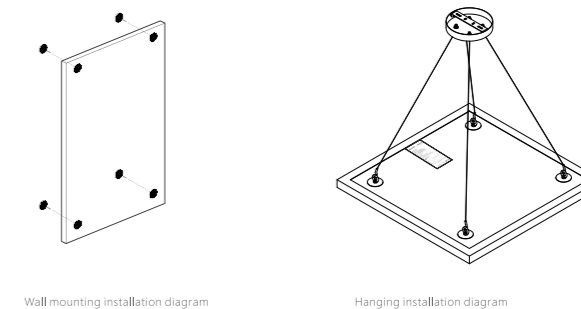

Size

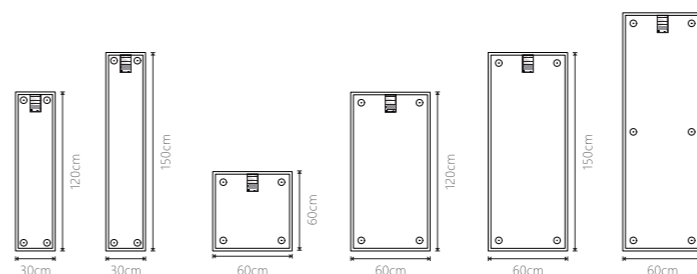

Reference

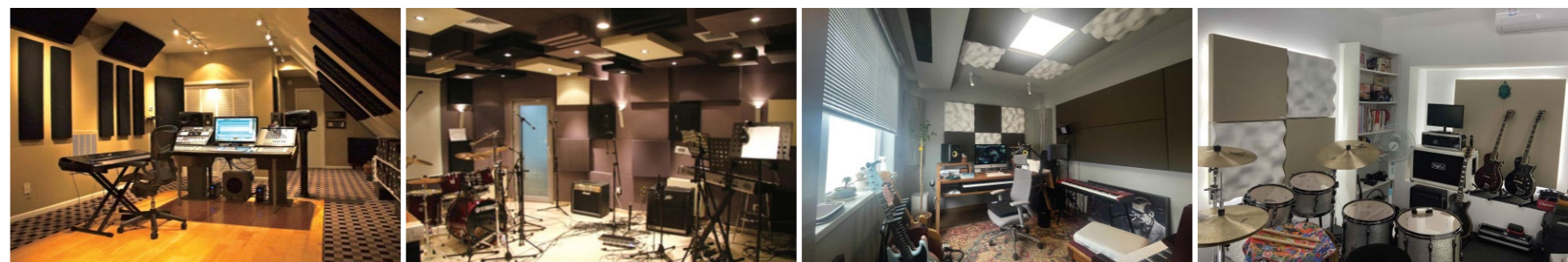
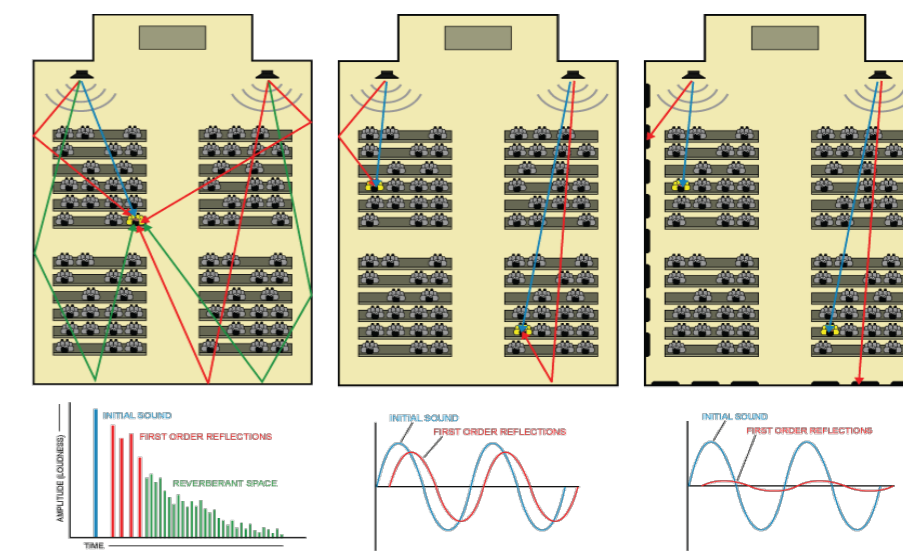
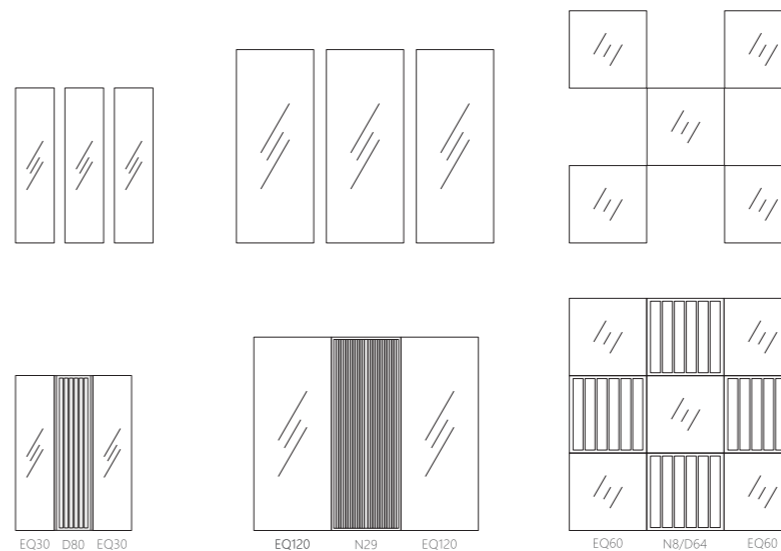



Name: Rococo
Model: EQ50R
Base Material: ECO-friendly composite acoustic wool of different density
Finish: SF-series, UA-series, YC-series fabric acoustic cloth surface finishing
Eco-Friendly: Zero Formaldehyde emission; Up to Enf standard
Specification: Refer to standard specifications (non-standard customized quantity ≥ 10m²)
Weight: ≤5kg/m²

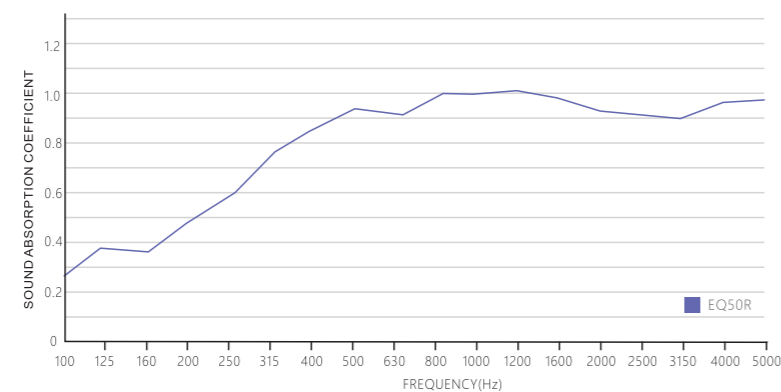

- Easy-to-install acoustic treatment solution that effectively controls the largest primary reflection in sound waves.
- Using high-density natural micro-porous fiber environmentally friendly acoustic cotton, the composite inner structure conforms to the acoustic index.
- Combined with the huge absorption surface area of the broadband tuning plate. It can effectively improve the sound superposition of reverberation and excessive echo generated by a large sound pressure level.
- The variety of combined installation methods perfectly cover the sound reflection wall, absorb a large amount of reflected sound waves, and restore the natural atmosphere of the hall. It is especially suitable for the transformation of the acoustic environment in large spaces with broadband attenuation and reverberation.

The Rococo style first appeared in decorative arts and interior design. Compared with the early Baroque and the later neoclassical, Rococo reflected the intertwined atmosphere of social pleasure, luxury and love at that time, and added a lot of exotic flavors in the creation. Elements. The overall characteristics of Rococo are brisk, gorgeous, delicate, delicate, cumbersome, slender, and soft, pursuing light and slender beauty, delicate and charming, complicated and delicate, delicate and elegant, sweet and gentle, intentionally emphasizing asymmetry in the composition, and its craftsmanship. , structure and lines are tactful and soft. Our product can produce a good tuning tool for your room reverberation time, eliminating fluttering echo and standing waves, while preserving beneficial reflection through scattering, but also helps to solve the problem of over absorption, keeping the sense of fullness and space. Our products are a result of deeply felt responsibility towards architectural design, geometrical shaping and aesthetic factor.

Size

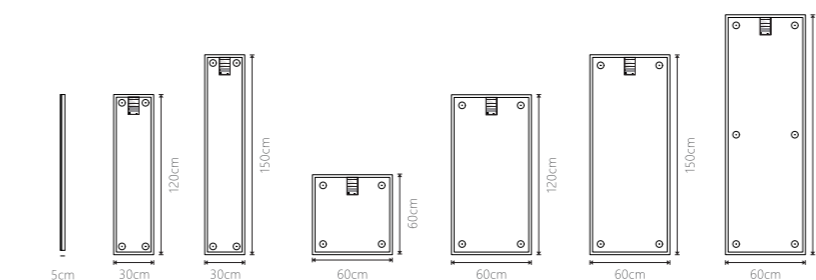

Installation guidelines

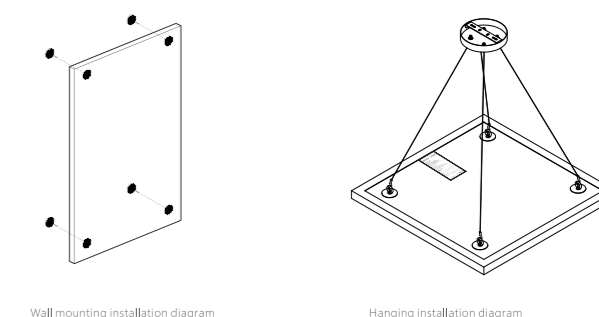

Reference

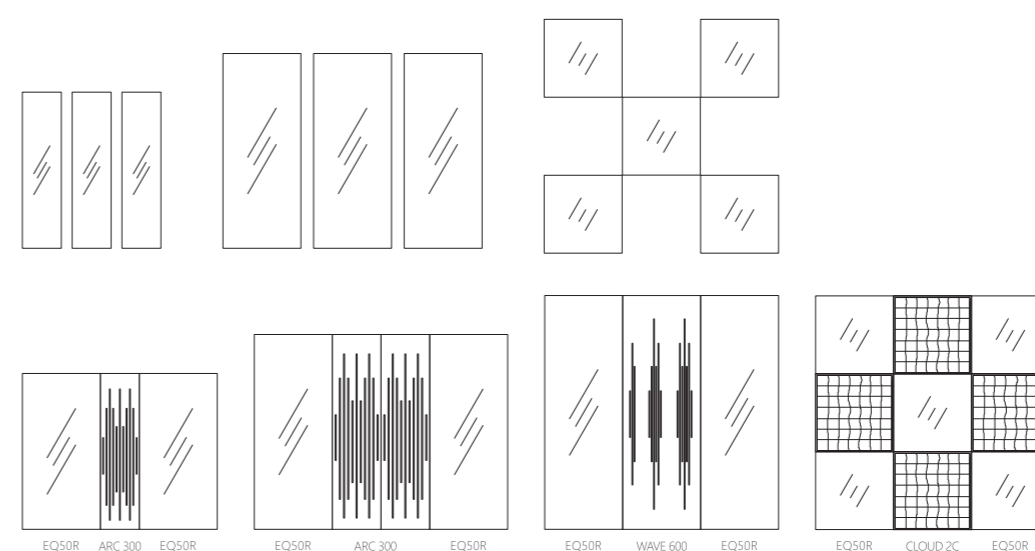



Name: Baroque
Mosdel: EQ50B
Base Material: 100% eco-friendly acoustic composite fiber wool
Finish: SF-series, YC-series fabric acoustic cloth surface finishing
Eco-Friendly: Zero Formaldehyde emission; Enf standard
Specification: Refer to standard specifications (non-standard customized quantity $\geq 10m^2$)
Weight: $\leq 5Kg/m^2$

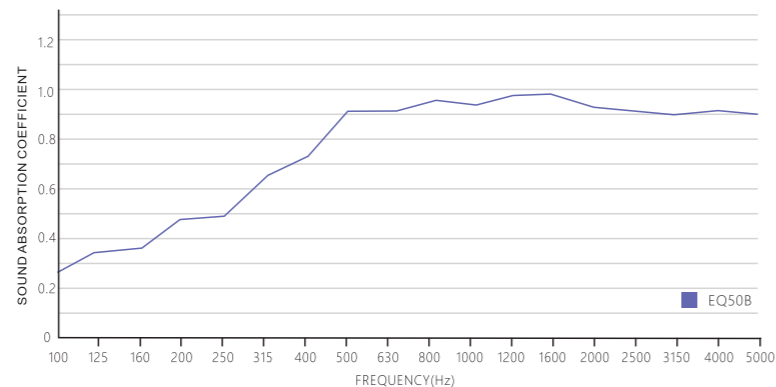

- Our product integrates mixed density acoustic linen and high density porous green wool in an airtight internal structure.
- Since our product is design in modular form, the combination is diversified and suitable for tuning the broadband frequency in large spaces. With its highly effective absorption capability, our product will transform your listening experience with natural hall impression.
- 3D absorbing structure on the surface helps Walleasear to solve reverberation generated from great sound pressure and superposition arising therefrom.
- By extending our accessories to the back cavity, we can increase the absorption frequency spectrum by one octave (75Hz at the lowest), transforming it into a low frequency trap that can handle vast range of audio.

Baroque's philosophy is deeply affected by Renaissance thought, which is based on the idea of romanticism, the style of Baroque is full of luxurious decoration with grace temperament. It shows the character of religion and hedonism at the same time to heighten an open and passionate living atmosphere. After Baroque decade, Classical musicians tended to simplify and standardize musical language. In other words, diversification and change are the soul of Baroque art.

Our product can produce a good tuning tool for your room reverberation time, eliminating fluttering echo and standing waves, while preserving beneficial reflection through scattering, but also helps to solve the problem of over absorption, keeping the sense of fullness and space. Our products are a result of deeply felt responsibility towards architectural design, geometrical shaping and aesthetic factor.

Size

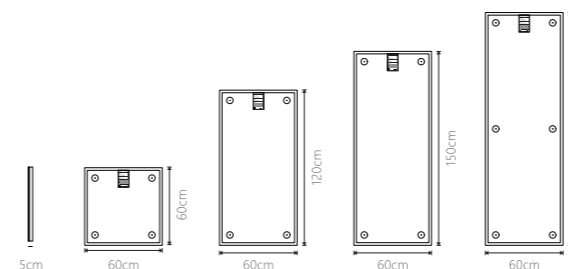

Installation guidelines

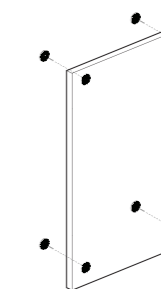

Reference

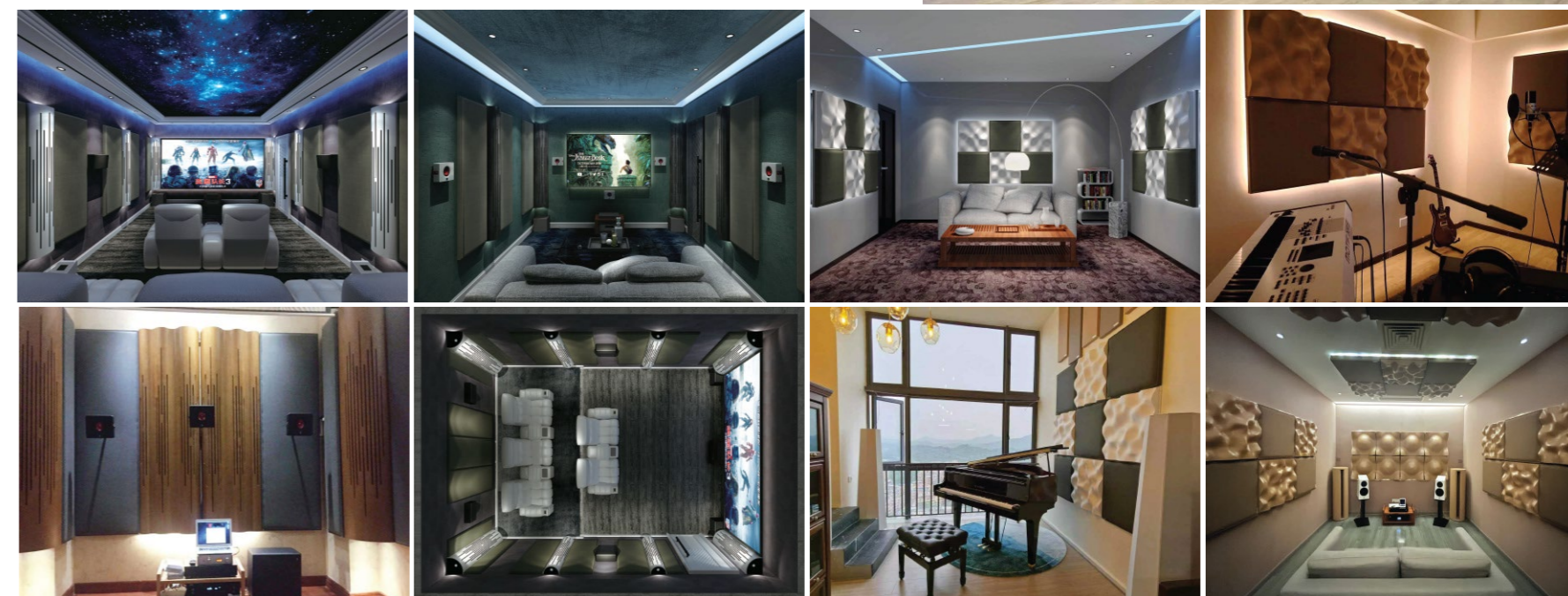
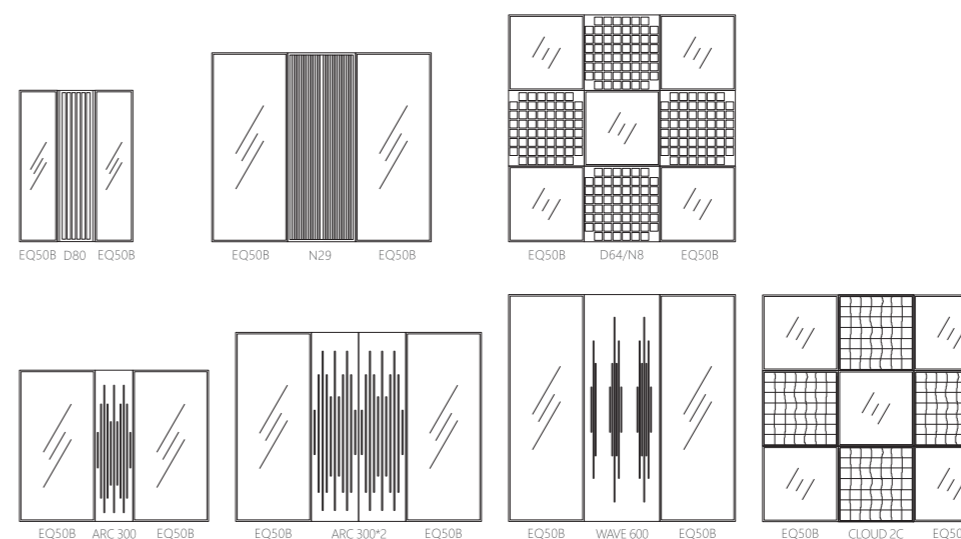



Name: Versailles
Mosdel: EQ50Q
Base Material: Purely natural green fiber acoustic wool
Finish: SF-series, YC-series fabric acoustic cloth surface finishing
Eco-Friendly: Zero Formaldehyde emission; Up to Enf standard
Specification: Refer to standard size (not accept customized size)
Weight: ≤5Kg/m²

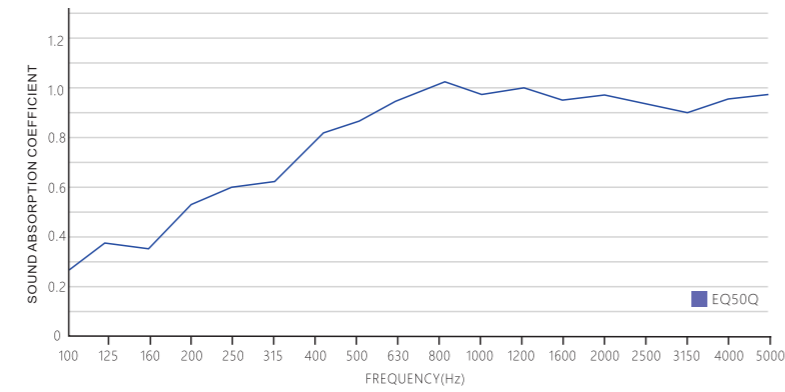

- Our product shows not only excellent acoustic characteristics, but also the organic combination of art and technology.
- Integrate into the spaces easily to achieve diverse spatial acoustic indicators.
- Easy to build a broadband absorption wall to control the powerful main reflection.
- A variety of standard specifications and size customization, suitable for the establishment of equal acoustic absorption in different spaces.
- Standard sized one suits to create a wall for main reflection and to form a surface in the ratio of 1(Absorption):1(Diffusion).
- Other optional size is available for setting up a balanced absorbing surface e.g. church, hall, entertaining room, office, house, studio, private cinema etc

'Versailles' are finished with random crack convex surface, which forms plenty different absorber to eliminate broader frequency spots, medium frequency fluttering echoes and low frequency standing waves. In this way, it helps effective control for reactivation between sound reflection source and listener. 'Versailles' is an easy-to-install and yet effective solution Installation: Usually, 'Versailles' is flush mounted on walls together with diffusers so that it will maximize the potential of beneficial reflections. Here we had eliminated the dilemma of acoustic controlling and full sense of a room keeping. 'Versailles' is suitable to solve main reflection on medium sized spaces like home cinema, studio and entertaining room. Our products are a result of deeply felt responsibility towards architectural design, geometrical shaping and aesthetic factor.

Size

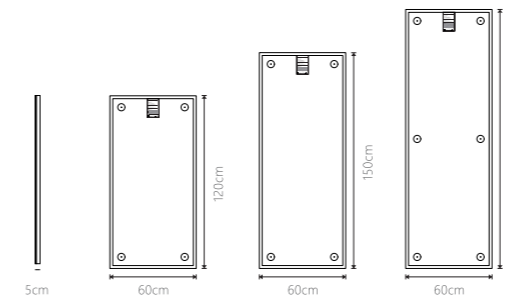

Installation guidelines

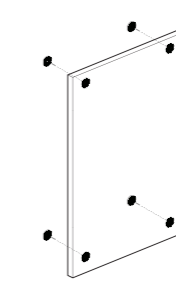

Reference

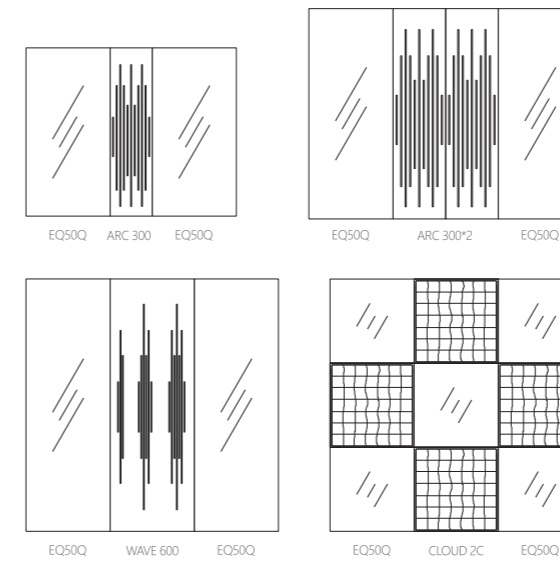



Name: Mirage
Mosdel: EQ2.1 / EQ2.2 / EQ2.3 / EQ2.4(Plus)
Base Material: Purely natural green fiber acoustic wool
Finish: UA-series, 14 series, SF-series, fabric acoustic cloth surface finishing
Eco-Friendly: Zero Formaldehyde emission; Up to Enf standard
Specification: Refer to standard specifications (non-standard customized quantity ≥ 15m²)
Weight: ≤6.3Kg/m²

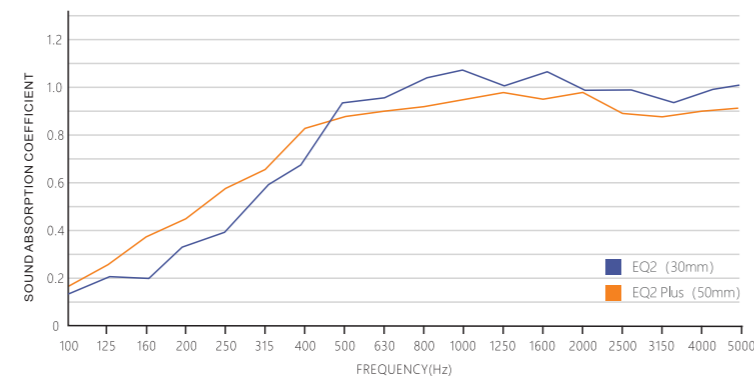

COLOR



- The flat soft surface is the perfect "companion" for hard walls, which can effectively prevent sound reflection and reduce reverberation time.
- Four-layer non-equivalent density composite base material, it is conducive to enhancing the absorption of sound energy in a wider frequency band and forming a strong sound-absorbing wall.
- Unique closed acoustic cavity design to increase the absorption of low-frequency residual sound energy. Patented aluminum frame structure to ensure maximum absorption surface area and acoustic performance.
- Zero formaldehyde emission, E0 standard environmental protection base material, to ensure the safety of the sound environment.
- Application : office, conference room, reception space, leisure room, home cinema, studio etc



Size

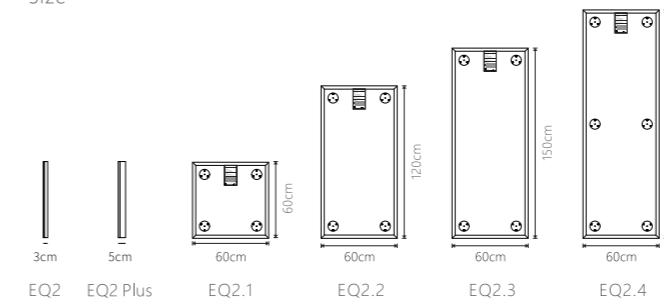

Package

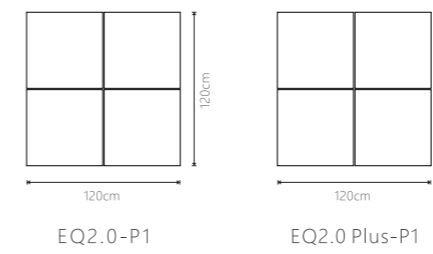

Reference

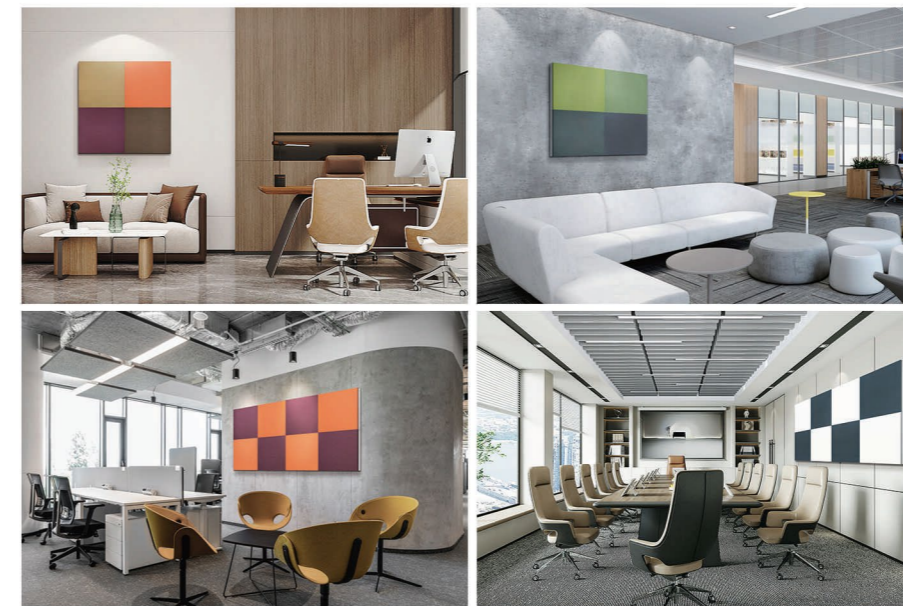
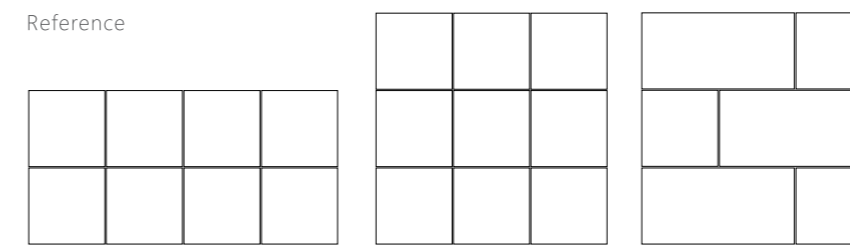

Installation guidelines

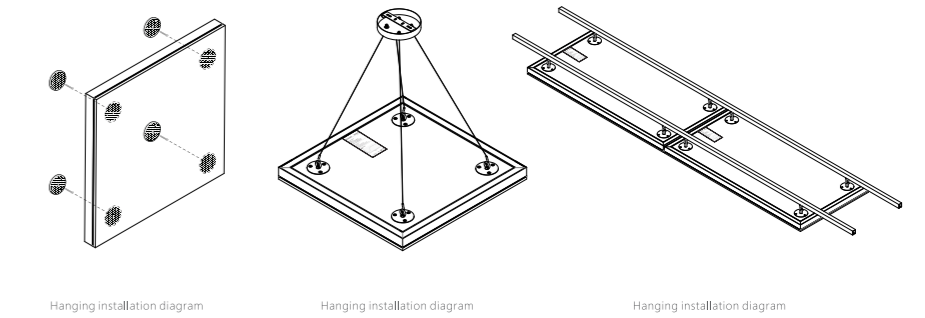

PACKAGE





Name: Phantom
Mosdel: EQ3.1 / EQ3.2 / EQ3.3 / EQ3.4
Base Material: Purely natural green fiber acoustic wool
Finish: 14 series, SF-series, fabric acoustic cloth surface finishing
Eco-Friendly: Zero Formaldehyde emission; Up to Enf standard
Specification: Refer to standard specifications
Weight: EQ3.1≤3.4Kg, EQ3.2≤4.7Kg, EQ3.3≤5.9Kg, EQ3.4≤12Kg

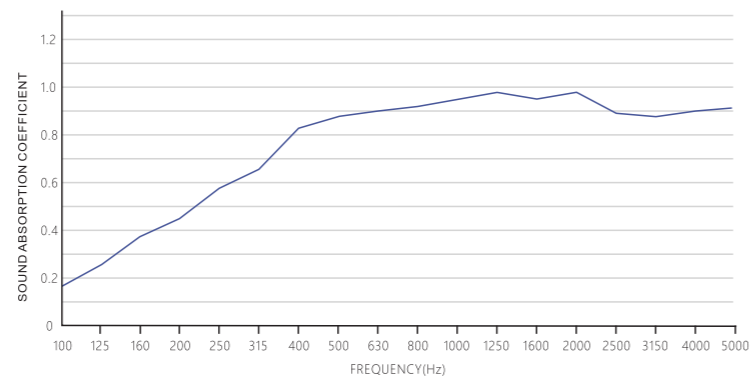

COLOR



- The "phantom" is a combination of rigorous acoustics and technology aesthetics.
- Quickly control the main reflected waves on the wall, it improves the language intelligibility effectively.
- Unique rear acoustic cavity design to increase the absorption of low-medium frequency residual sound energy.
- Streamlined steel structure, optional side lighting background ambient light, make the acoustics without losing the aesthetics.
- The combination of magic methods provides infinite fantasy space, and arbitrarily builds an absorbing wall that integrates into the environment.
- Zero formaldehyde emission, E0 standard environmental protection base material, to ensure the safety of the sound environment.
- Application : office, conference room, reception space, leisure room, home cinema, studio etc

Size

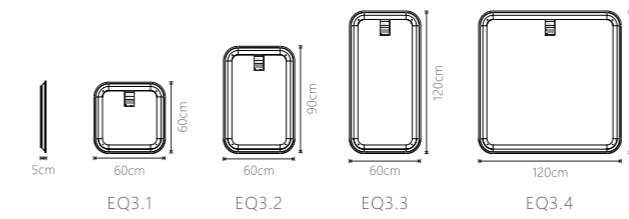

Installation guidelines

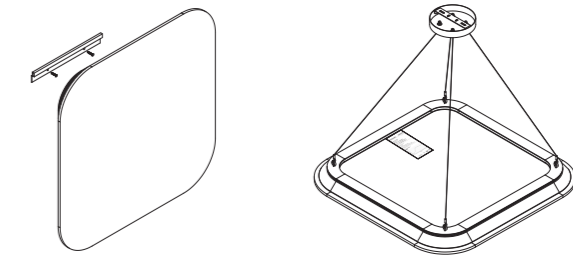

Hanging installation diagram

Hanging installation diagram

Package

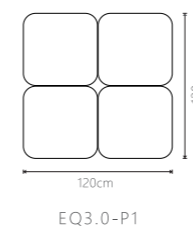

Reference

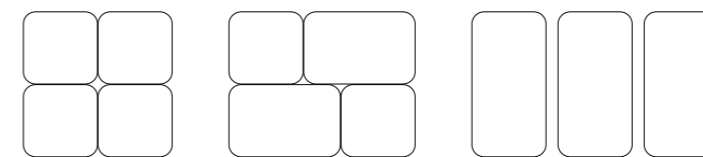

PACKAGE

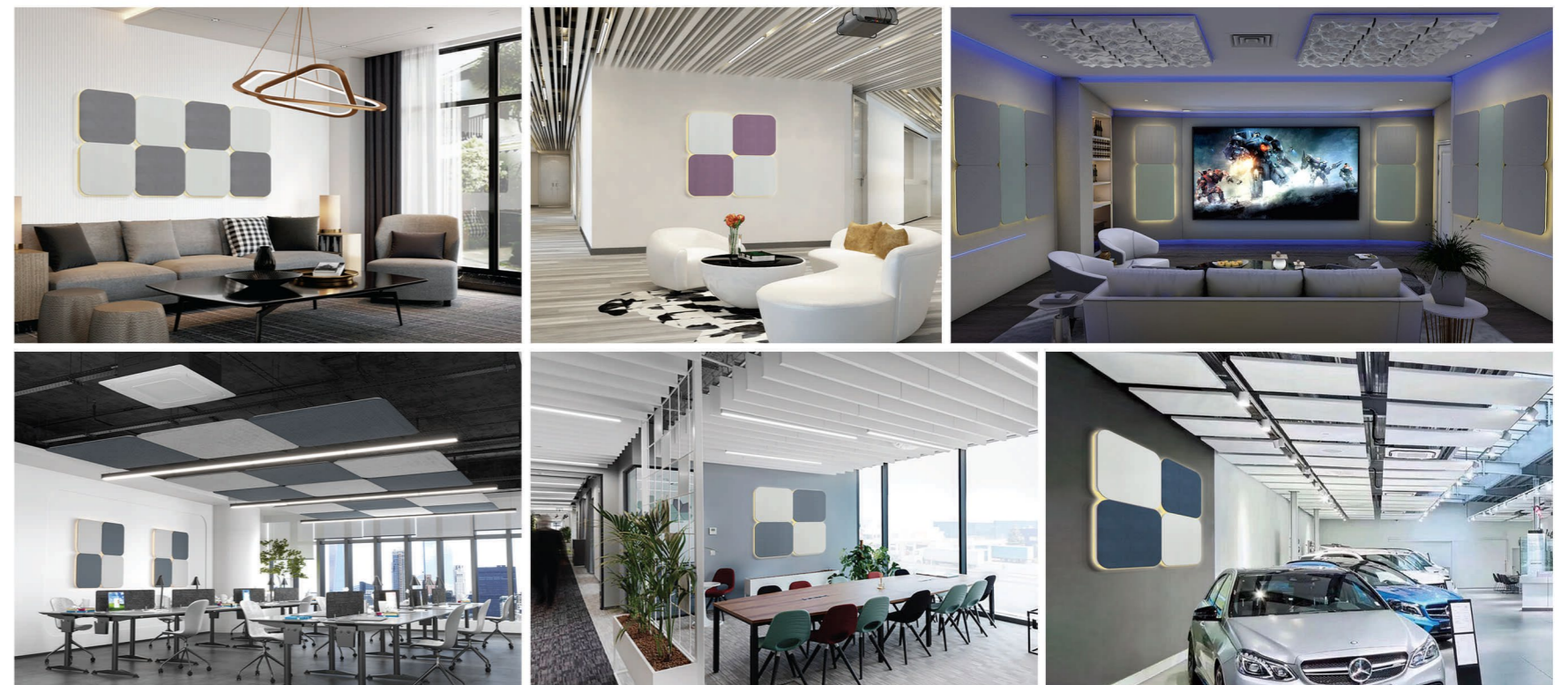
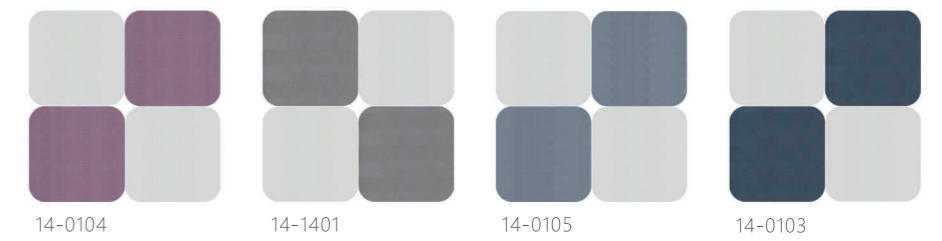

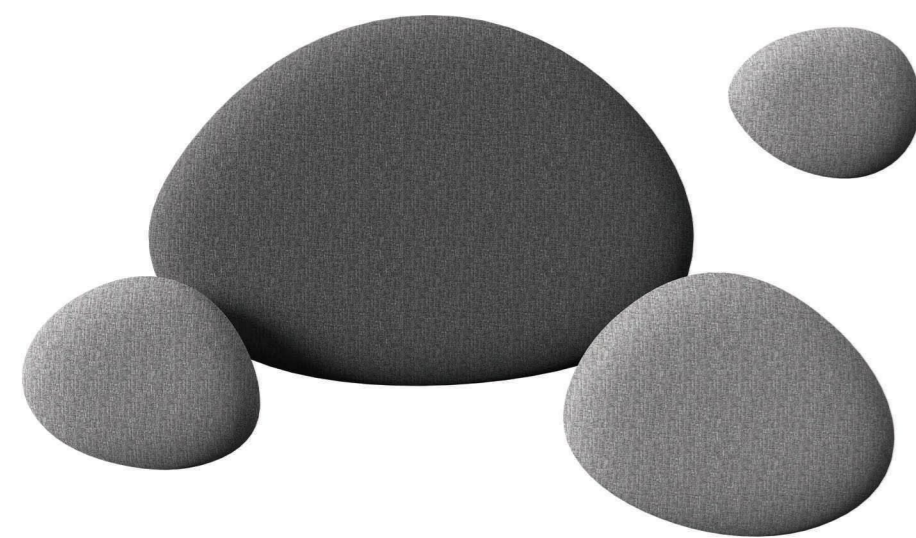

Name: Cobble
Mosdel: EQ4.1/ EQ4.2 / EQ4.3/ EQ4.4
Base Material: Purely natural green fiber acoustic wool
Finish: SF-series, fabric acoustic cloth surface finishing
Eco-Friendly: Zero Formaldehyde emission; Up to Enf standard
Specification: Refer to standard specifications
Weight: EQ4.1≤0.43Kg, EQ4.2≤0.65Kg, EQ4.3≤1.09Kg, EQ4.4≤3.57Kg

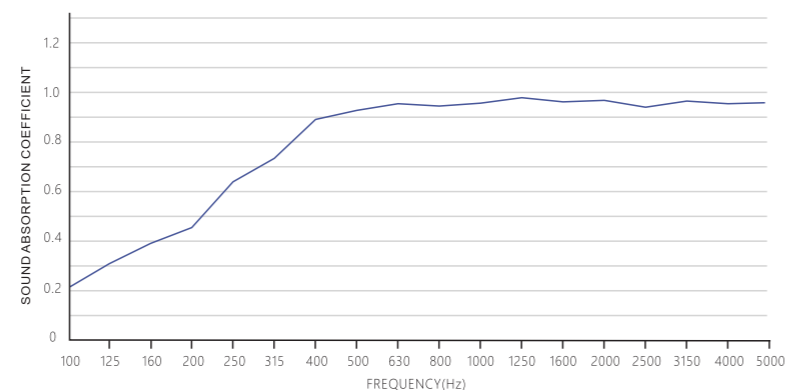

COLOR

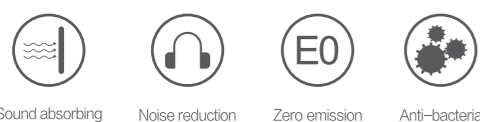

- It not only offers well performed acoustical function with aesthetics, but also deliver a perfect combination when it is applied into different spaces with design.
- The installation is easy with standard anti-oxidization and anti-resonance treated aluminum fixing system.
- Powerful broadband absorption performance can easily build a professional sound-absorbing surface.
- Flexible and free combination with acoustic solutions, covering the main reflection surface and reducing the spatial reverberation phenomenon.
- Application : Home, office, conference room, reception space, leisure room, home cinema, studio etc

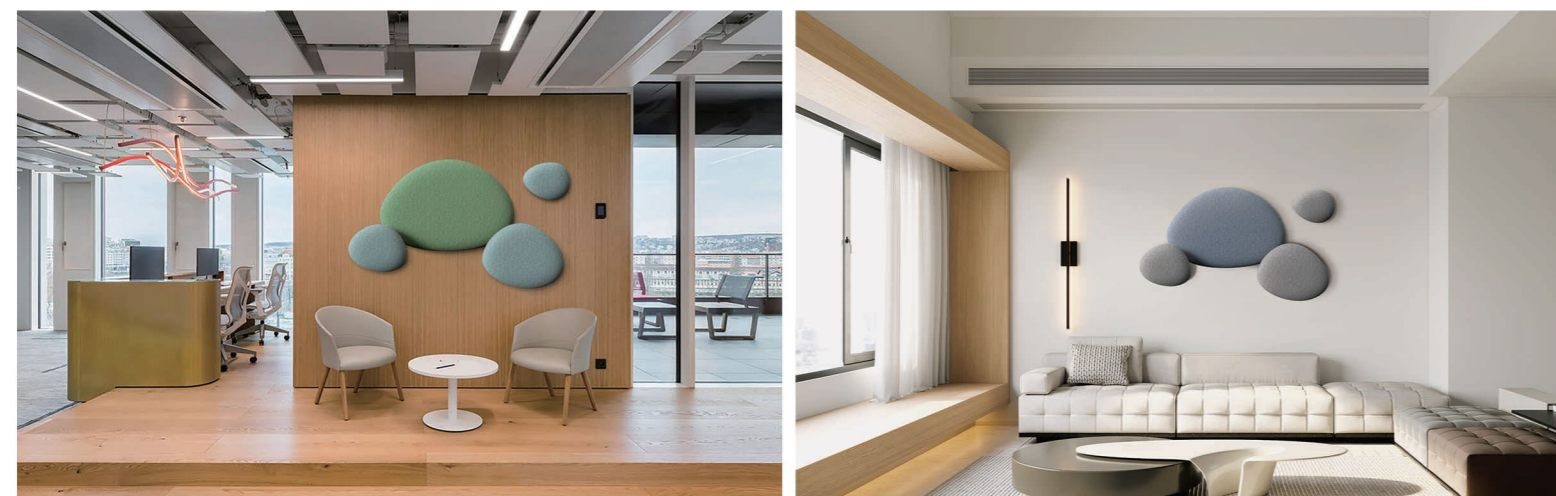

Size

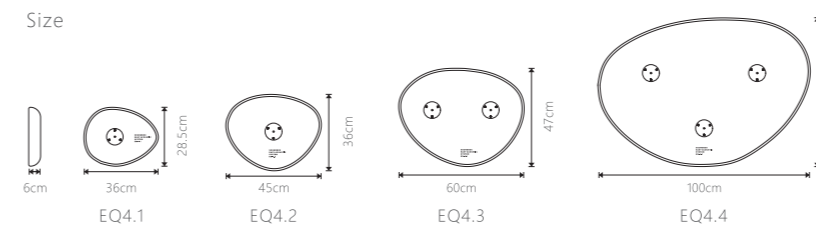

Package



Installation guidelines

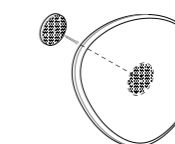

Reference

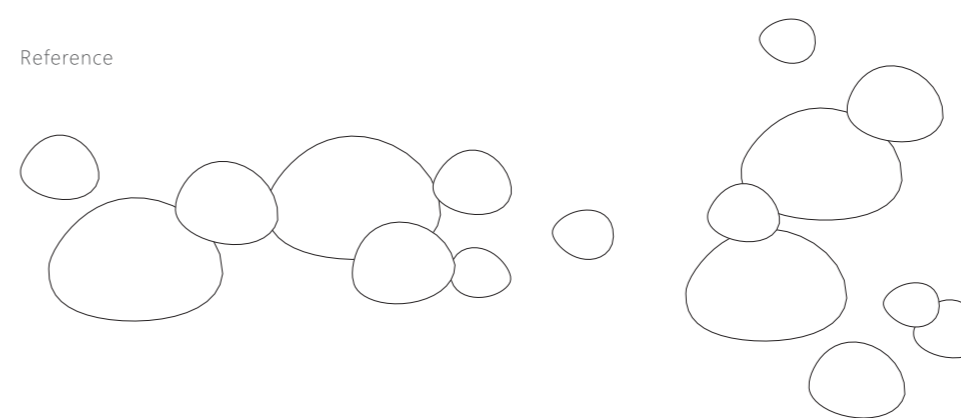

PACKAGE





Name: Geometric
Model: EQ5.1Q / EQ5.2Q / EQ5.1R / EQ5.2R
Base Material: Purely natural green fiber acoustic wool
Finish: SF-series, fabric acoustic cloth surface finishing
Eco-Friendly: Zero Formaldehyde emission; Up to Enf standard
Specification: Refer to standard specifications
Weight: H600≤1.96Kg, H900≤3.64Kg, R600≤1.52Kg, R900≤2.92Kg

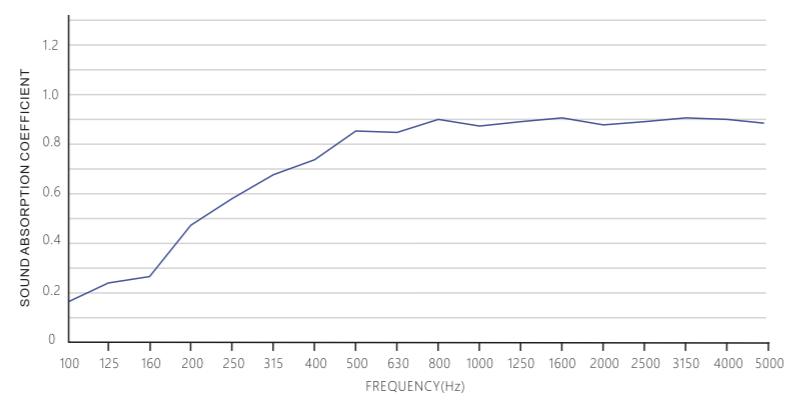

COLOR



- There are rules and regulations, self-contained.
- Rigorous functional data, easy to meet space acoustic standards.
- 6-years developed experiences, the combined material can absorb the broadband frequency perfectly.
- The installation is easy with standard anti-oxidization and anti-resonance treated aluminum fixing system and easy to build the acoustic environment.
- E0 standard eco-friendly standard with safety guarantee
- Application : office, conference room, reception space, leisure room, home cinema, studio etc



Size

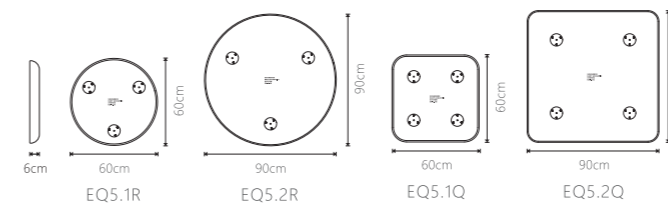

Package

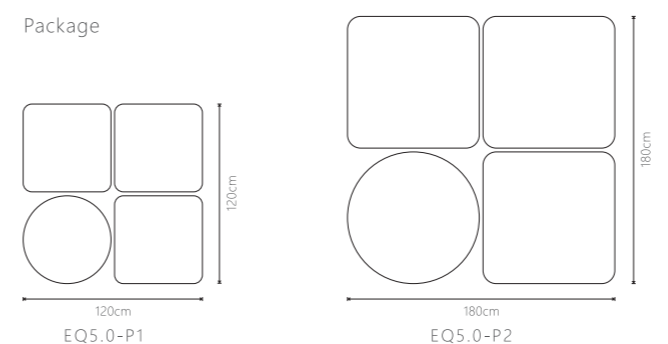

Reference

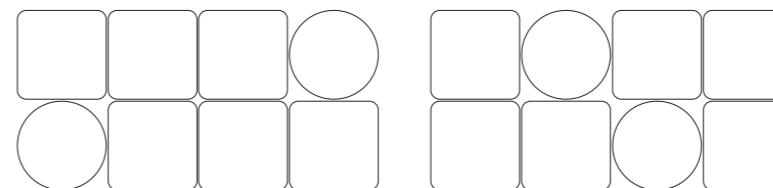

Installation guidelines

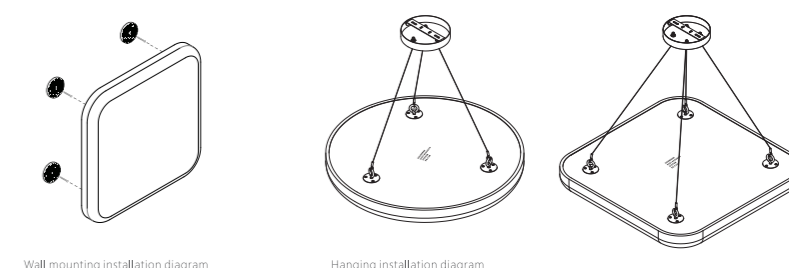

PACKAGE

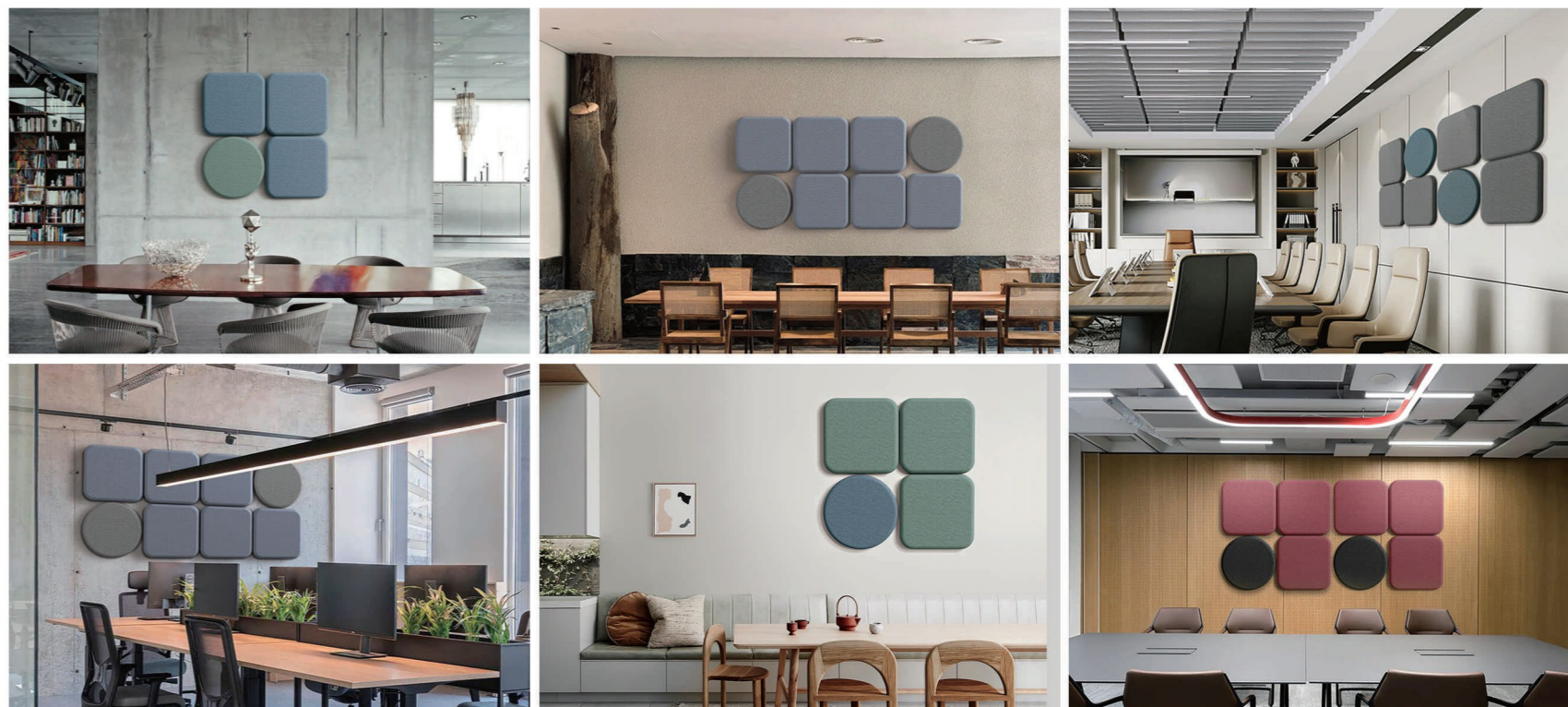
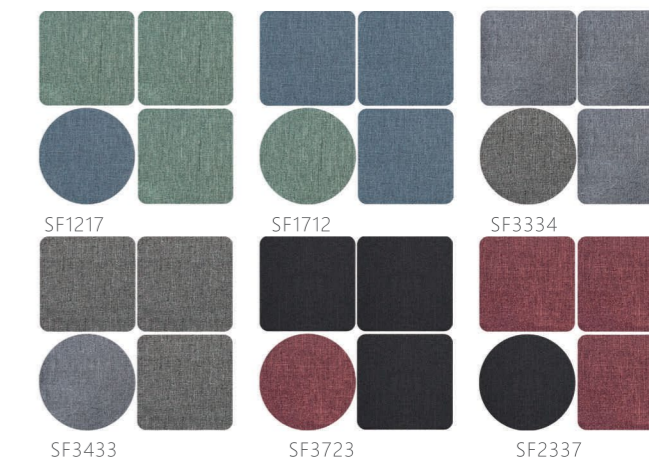

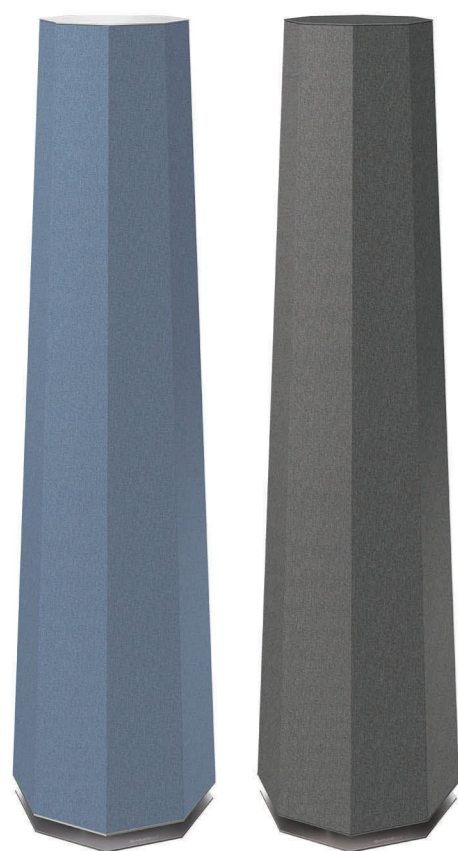

101A 101B

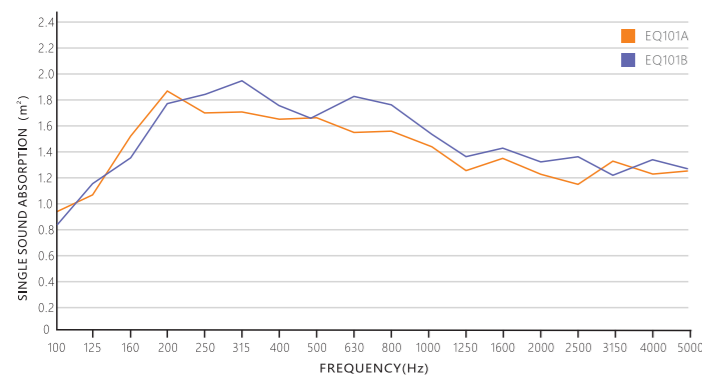

Name: Cylinder Basstrap
Model: EQ101A((Built-in Helmholtz resonator)) / EQ101B(Withou Built-in Helmholtz resonator)
Base Material: ECO-friendly composite acoustic wool of different density
Finish: SF-series, 14-series, fabric acoustic cloth surface finishing
Eco-Friendly: Zero Formaldehyde emission; Meet the international E0 standard
Size: H1500*W400*D250mm
Weight: EQ101A: ≤12.6Kg EQ101B: ≤12.7Kg
Acoustic structure: The eight-sided cone absorbing device and asymmetric volumetric structure can create a more advantageous broadband absorption cavity. The cylindrical 360-degree sound-absorbing surface absorbs the margin low-frequency waves gathered at the corners. Of course, the engineers have prepared the "A" option with a built-in Helmholtz resonator for you who are looking for higher spatial sound indicators, which better absorbs the 63Hz that is not liked by sound recordists and burners, even if the presence of these frequencies is not of public interest. The Cylinder Basstrap acts on the absorption of low frequencies, and matches the EQ50R and other walleasear sound absorption panels perfectly, which is a perfect combination for building a high-quality sound environment in a small space.



EQ101A

EQ101B



102A 102B

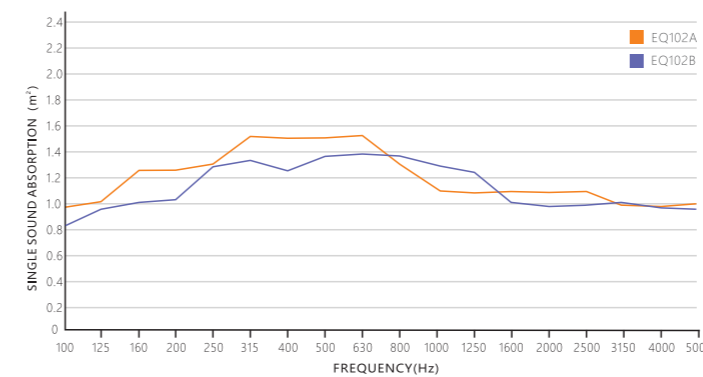

Name: Corner Basstrap
Model: EQ102A((Built-in Helmholtz resonator)) / EQ102B(Withou Built-in Helmholtz resonator))
Base Material: ECO-friendly composite acoustic wool of different density
Finish: 14-series, SF-series, fabric acoustic cloth surface finishing
Eco-Friendly: Zero Formaldehyde emission; Meet the international E0 standard
Size: H1500*W400*D250mm
Weight: EQ102A: ≤15Kg EQ102B: ≤15.3Kg
Acoustic structure: The Four-sided trapezoidal strong absorbing device, asymmetric volumetric structure acts to create a more advantageous broadband absorption cavity. The cylindrical 360-degree sound-absorbing surface absorbs the margin low-frequency waves gathered at the corners. Of course, the engineers have prepared the "A" option with a built-in Helmholtz resonator for you who are looking for higher spatial sound indicators, which better absorbs the 63Hz that is not liked by sound recordists and burners, even if the presence of these frequencies is not of public interest. The Cylinder Basstrap acts on the absorption of low frequencies, and matches the EQ3.0 and other walleasear sound absorption panels perfectly, which is a perfect combination for building a high-quality sound environment in a small space.



EQ102A

EQ102B





Imagine acoustic painting is a natural acoustic cotton substrate made of natural plant ultra-fine fiber as raw material, mixed with 3% PET polyester fiber, and made of 280 degree high temperature and without glue heat compound. The substrate is double-sided with a 100% PET ultraporous acoustic trunk with a large number of unequal radius pores connected to each other, the pores are deep inside the structure, and the internal and external unequal orders of air layer constitute a wide frequency absorber. The layer of the substrate is also a good acoustic energy sealing structure, and the sound wave penetrates the surface layer to the ultra-micro-long radial pore, and the friction between the substrate material and the material converts the acoustic energy into heat energy, realizing the multi-stage reflection sound and noise that consumes excess space.

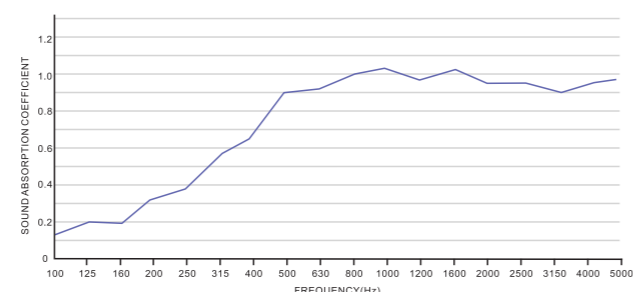

- Sound absorbing
- Noise reduction
- Zero emission
- Anti-bacteria



- Home furnishing
- Office
- Commercial
- Hotel
- Education
- Recuperate

EASY INSTALLATION

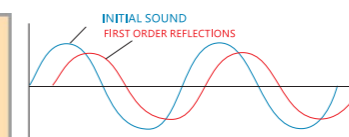
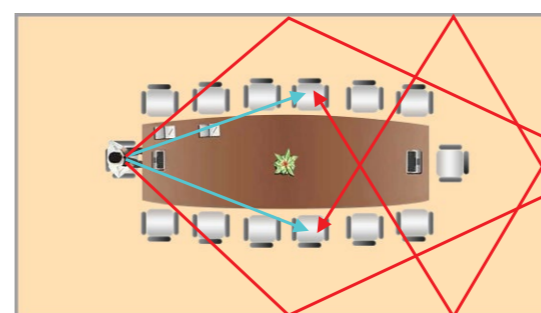
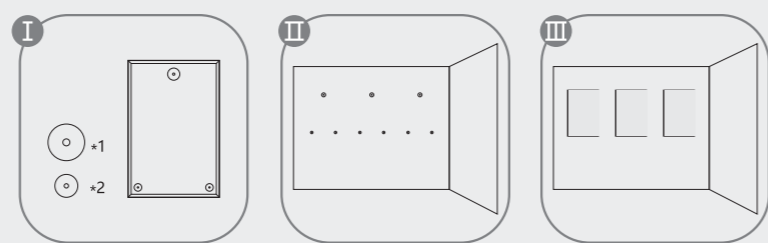

The initial direct sound (blue) overlaps with the powerful multi-order reflection sound (red) reverb. Severely interfering with the speaker linguistic clarity, such a space makes it difficult for the audience to experience the appeal of the language, especially in online meetings

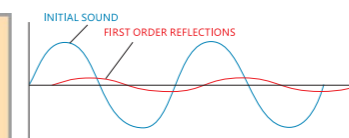
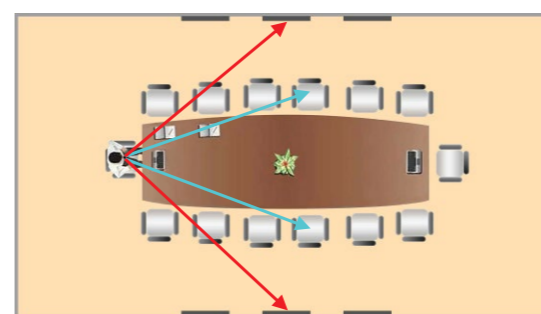

Imagine acoustic painting is installed to form a broadband wave absorbing wall, which effectively reduces the generation amplitude of multi-order reflected sound (red) in space and improves the language clarity by an order of magnitude. What's more, it has the important performance of strong absorption and elimination of background noise in space.

SPECIFICATION SELECTION

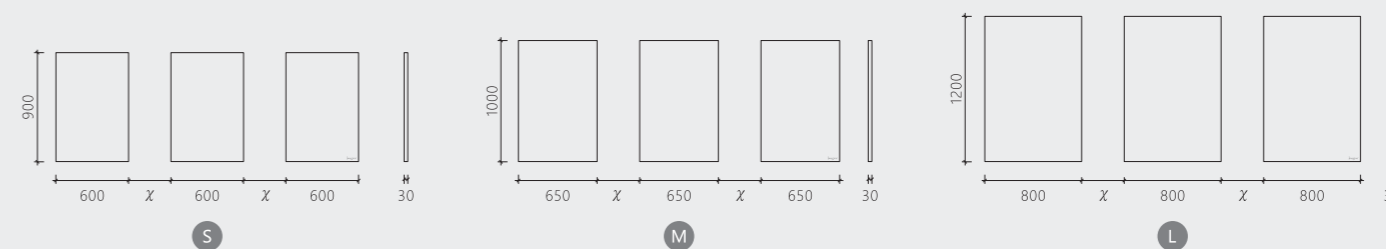

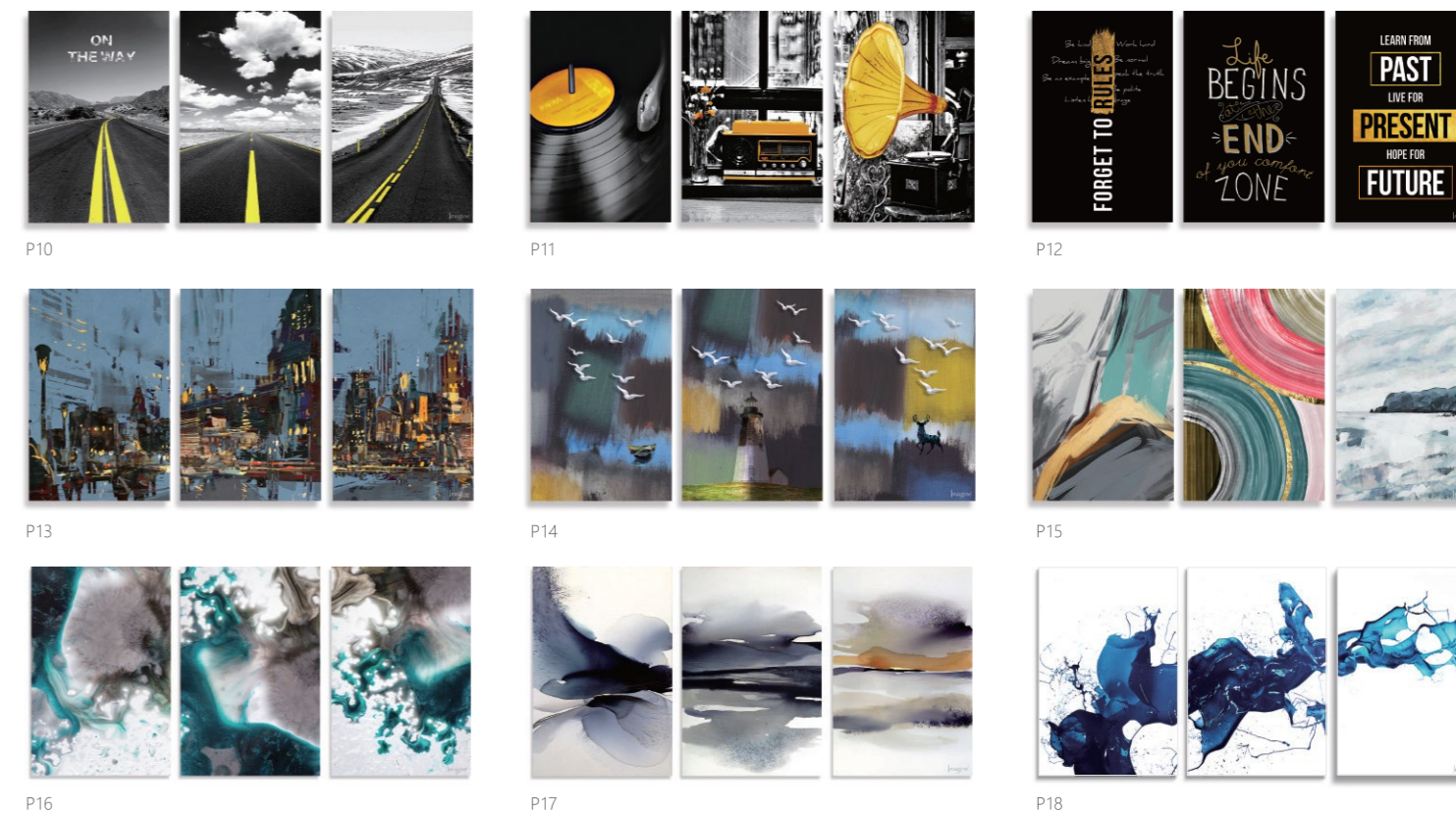

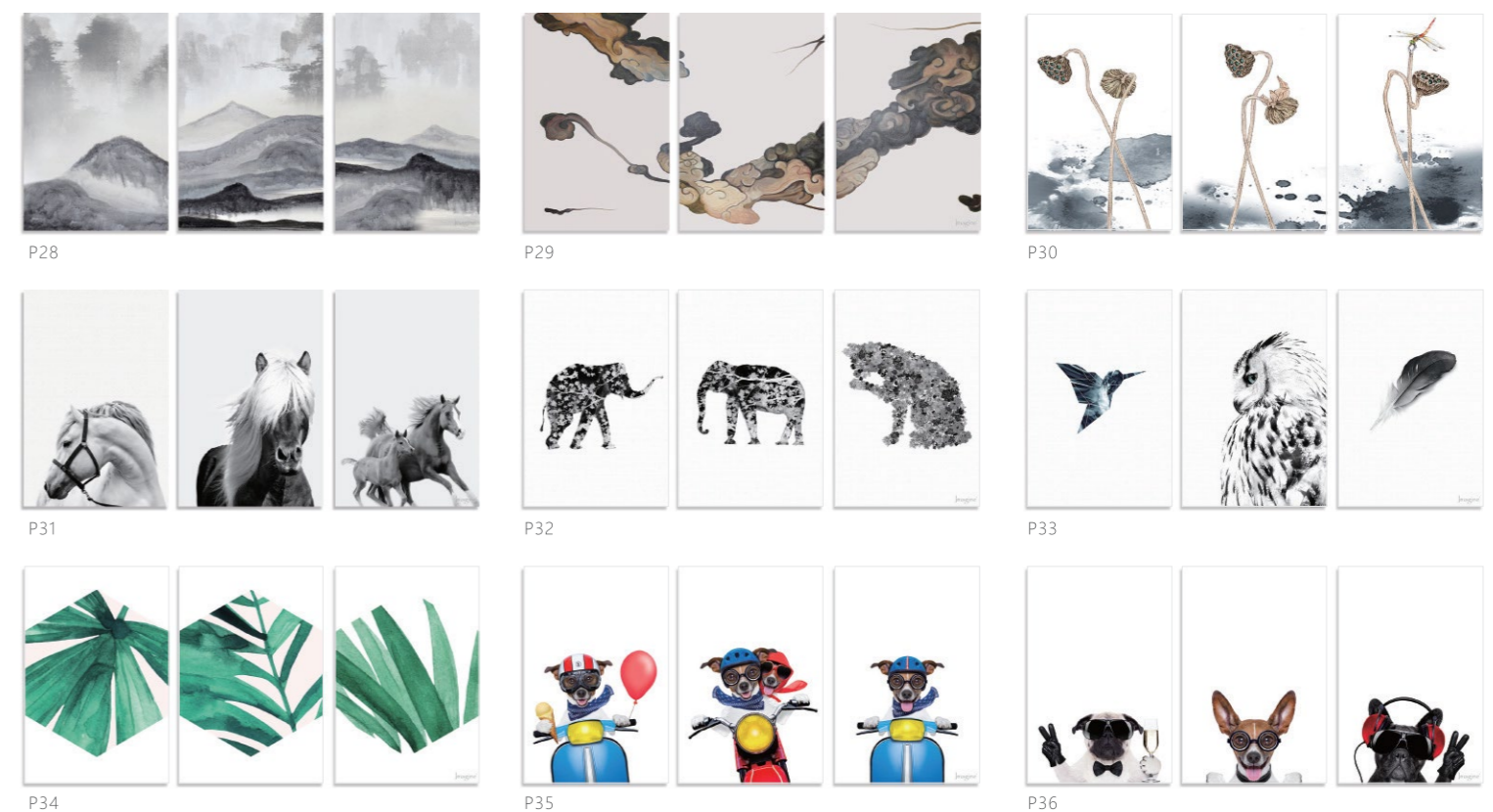
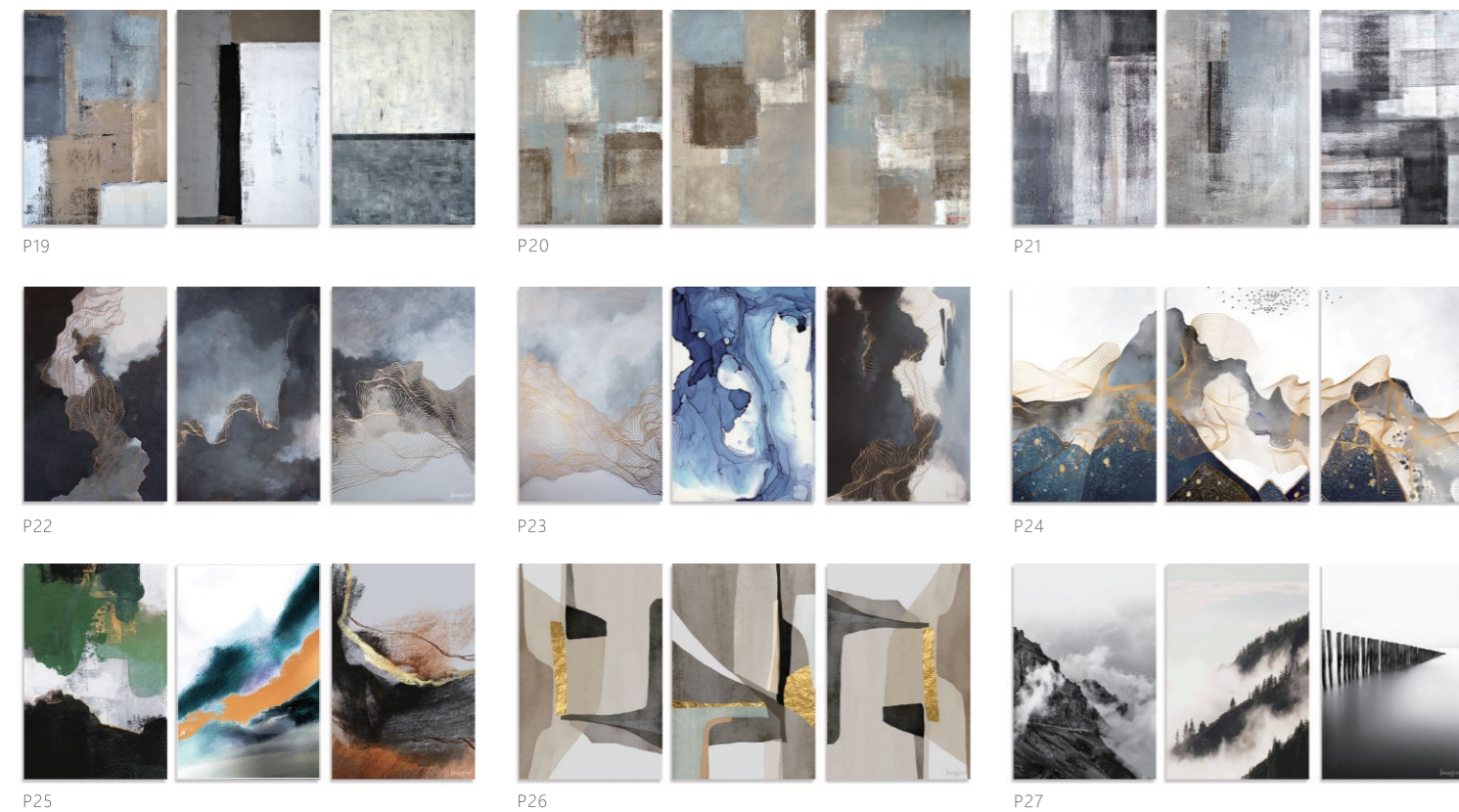

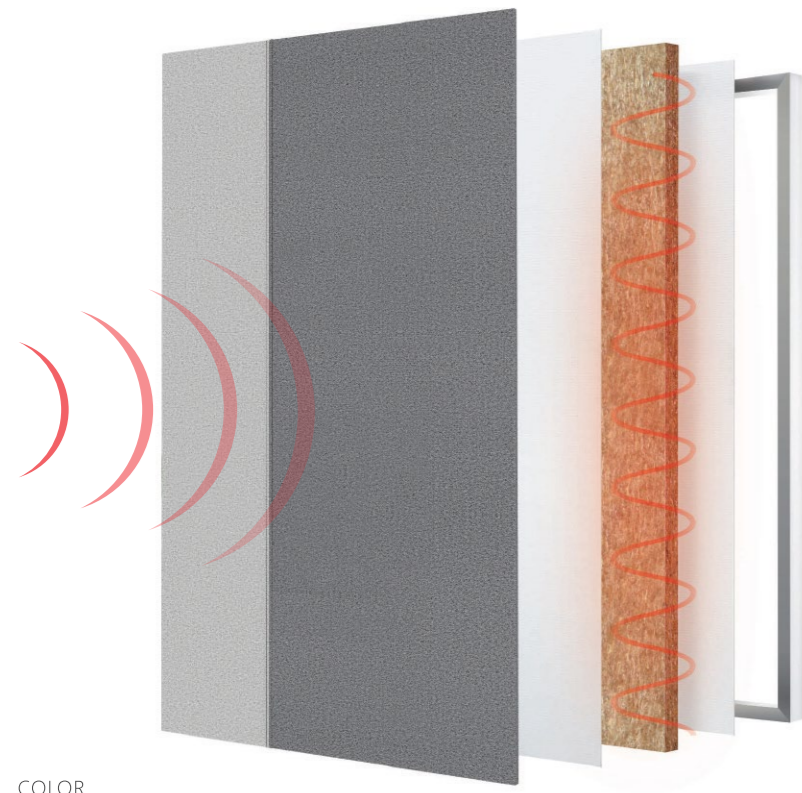

Imagine acoustic magic is a natural acoustic cotton substrate made of natural plant ultra-fine fiber as raw material, mixed with 3% PET polyester fiber, and made of 280 degree high temperature and without glue heat compound. The substrate is double-sided with a 100% PET ultraporous acoustic trunk with a large number of unequal radius pores connected to each other, the pores are deep inside the structure, and the internal and external unequal orders of air layer constitute a wide frequency absorber. The layer of the substrate is also a good acoustic energy sealing structure, and the sound wave penetrates the surface layer to the ultra-micro-long radial pore, and the friction between the substrate material and the material converts the acoustic energy into heat energy, realizing the multi-stage reflection sound and noise that consumes excess space.

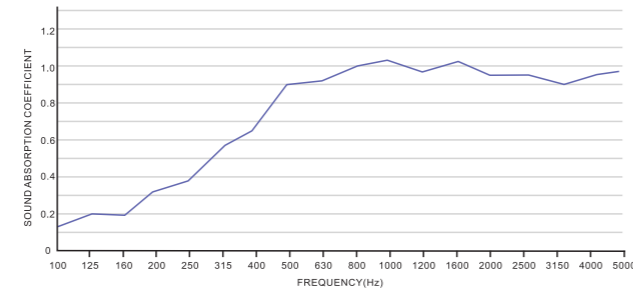

- Sound absorbing
- Noise reduction
- Zero emission
- Anti-bacteria

COLOR



- Home furnishing
- Office
- Commercial
- Hotel
- Education
- Recuperate

EASY INSTALLATION

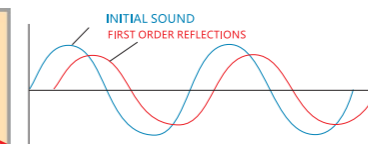
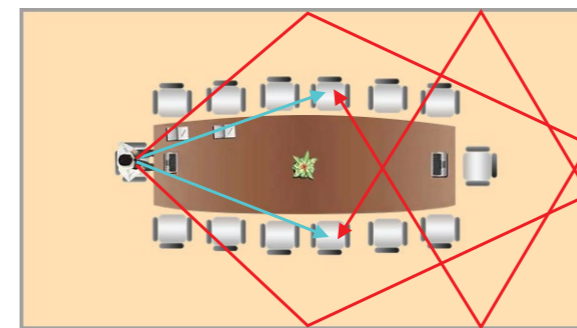
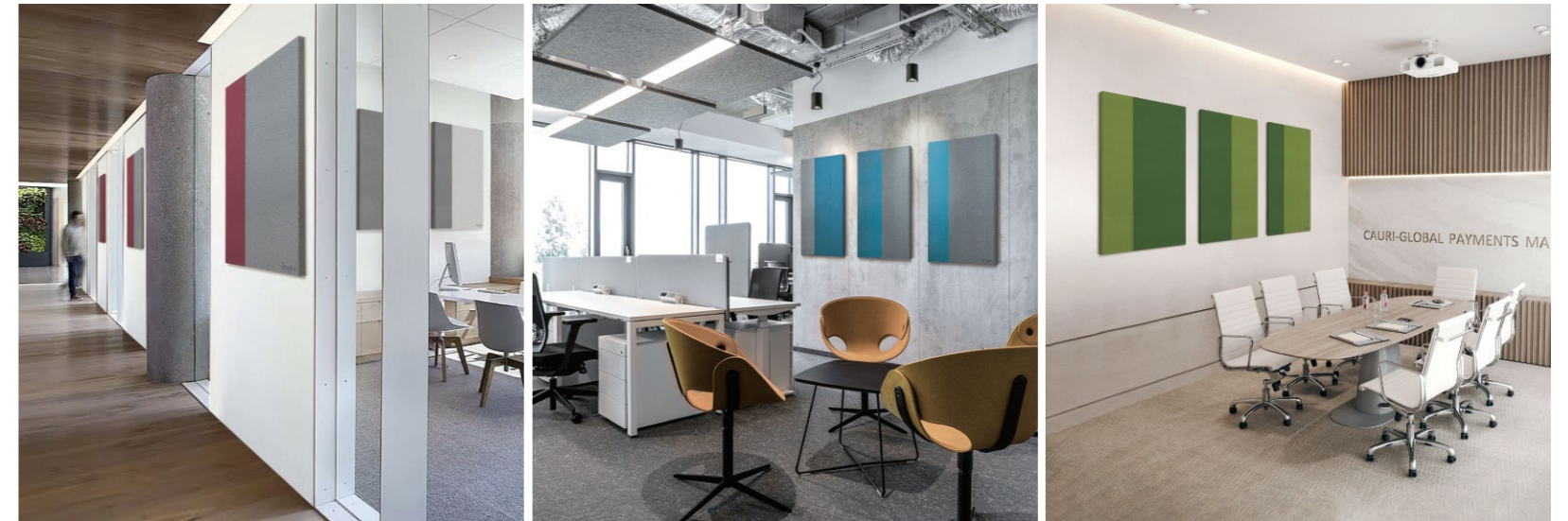
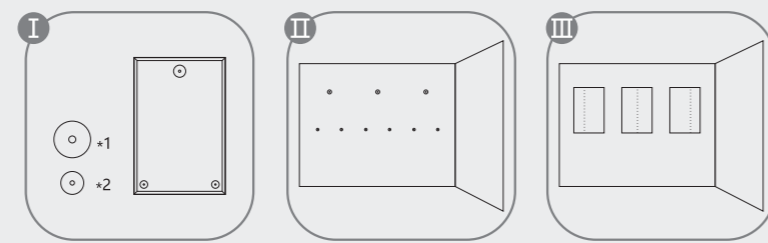

The initial direct sound (blue) overlaps with the powerful multi-order reflection sound (red) reverb. Severely interfering with the speaker linguistic clarity, such a space makes it difficult for the audience to experience the appeal of the language, especially in online meetings.

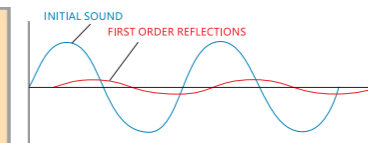
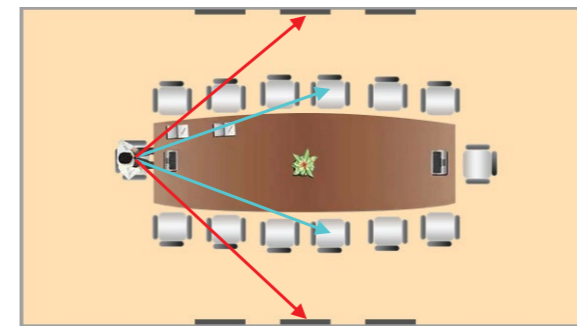

Imagine acoustic magic is installed to form a broadband wave absorbing wall, which effectively reduces the generation amplitude of multi-order reflected sound (red) in space and improves the language clarity by an order of magnitude. What's more, it has the important performance of strong absorption and elimination of background noise in space

SPECIFICATION SELECTION

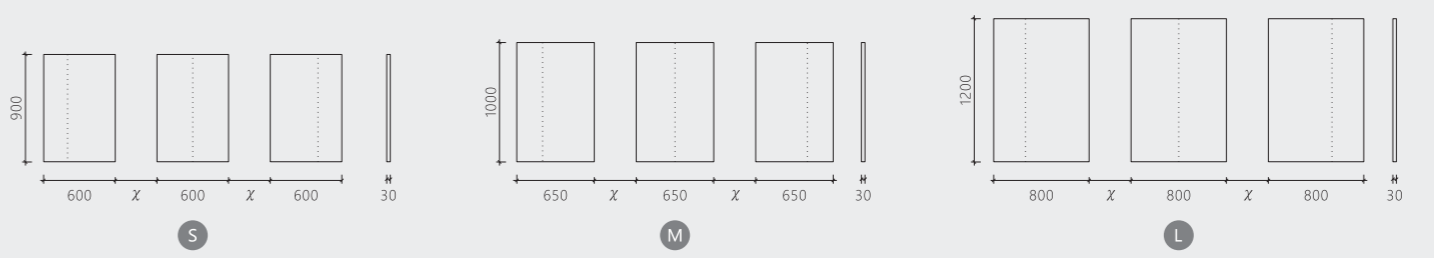

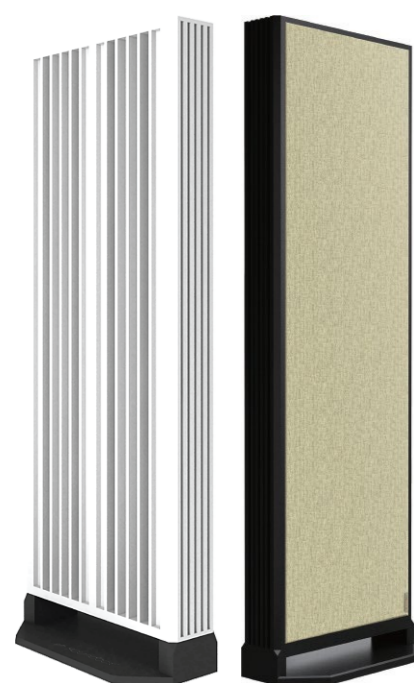

Name: Acoustic Baffle
Model: AQ1000S
Structure: Solid wood formation. Large version of QRD quadratic residue diffusion surface, three-step non-proportional cavity broadband sound absorption surface, labyrinth-type low-frequency trap with vibration damping base.
Finish: SF1200 Acoustical fabric for sound absorption; Diffusion side: Solid wood (Refer to color chart for details)
Eco-friendly: International E0 standard
Specification: H1600 * W600 * D150/350mm
Weight: 38Kg
Optional: Movable roller accessories can be installed on the base (purchased separately)
Application: Suits for controlling reverberation time and standing waves at the corner in small rooms, for example, listening rooms, studio and home theater. Moreover, it does well in sound absorption and diffusion when sound is being reflected.

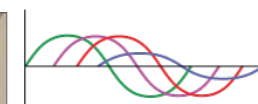
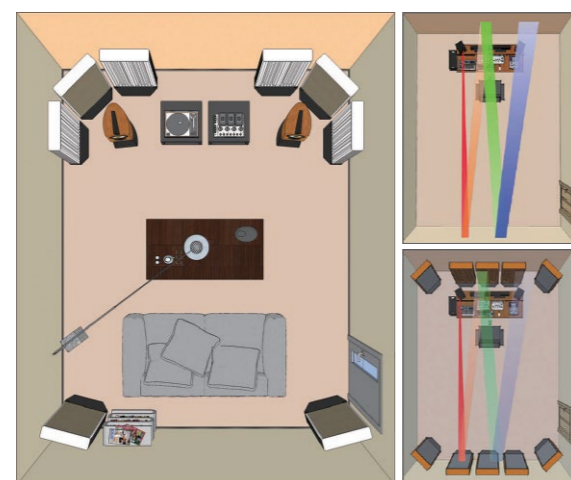
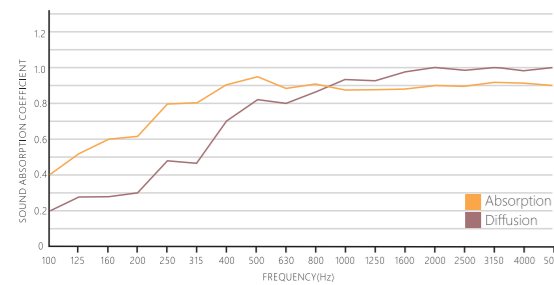

All the wrong kind sound reflection lean to excessive reverberation and amplitude of vibration, which makes sound location become difficult.

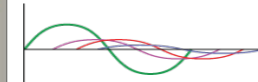

Our products can contro sound reflection and decrease standing wave in low frequency via acoustic treatment, improving acoustic enviroment in smll space.



Name: Haydn Acoustic Array
Model: AQ1000SL
Structure: Solid wood formation. Large version of QRD quadratic residue diffusion surface, three-step non-proportional cavity broadband sound absorption surface, labyrinth-type low-frequency trap with vibration damping base.
Finish: SF1200 Acoustical fabric for sound absorption; Diffusion side: Solid wood (Please refer to color chart for details)
Eco-friendly: International E0 standard
Specification: H2400 * W600 * D150/800mm
Weight: 71Kg
Application: Suits for bigger rooms, for example, listening rooms, studio and home theater.

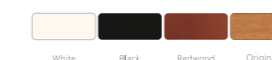

Sound energy needs to be cherished and used skillfully. It is difficult to achieve a pertinent spatial sound environment with single absorption, and it will also consume a lot of favorable sound energy, meaninglessly wasting the sound power of equipment. The AQ1000SL fully diffuses the powerful primary reflection sound, the non-proportional cavity broadband strong absorption surface deals with multiple reflection sounds that are not conducive to space, and the labyrinth-type low-frequency trap captures low-frequency standing waves that like to hide in corners. The movable and convenient design caters to your DIY smart ideas for space and sound.

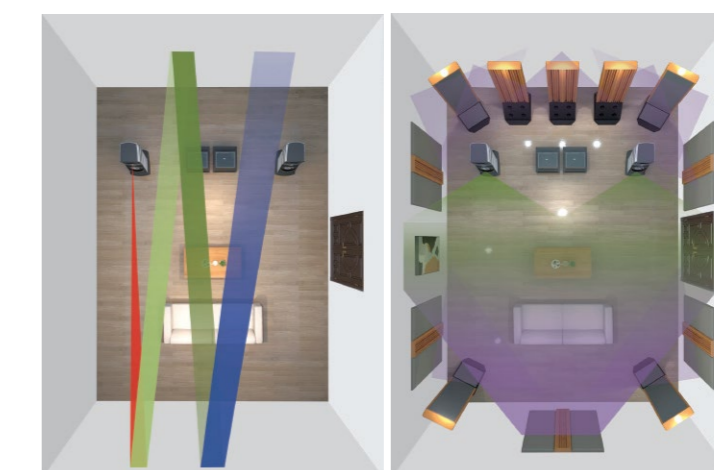

All the wrong kind sound reflection lean to excessive reverberation and amplitude of vibration, which makes sound location become difficult.

Our products can control sound reflection and decrease standing wave in low frequency via acoustic treatment, improving acoustic enviroment in small space.

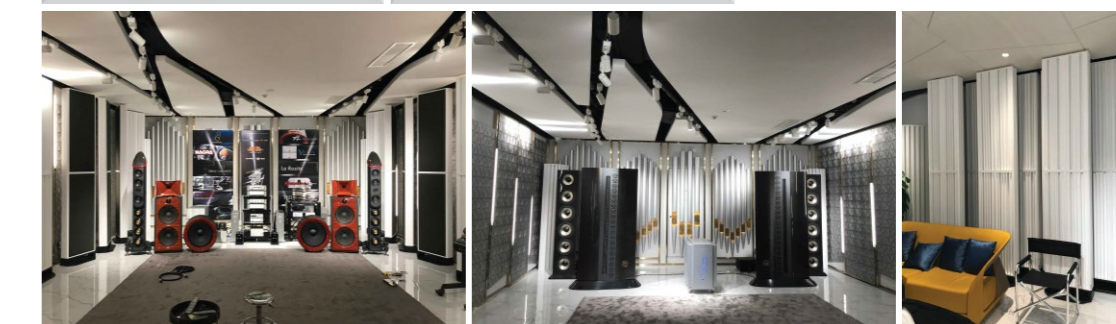



Name: Bach Acoustic Array
Mosdel: AQ1000SW
Structure: The high-density solid wood structure is composed of three-section structures of medium and high frequency diffusion, medium and low frequency absorption cavities.
Finish: 268-12 Acoustical fabric for sound absorption;
Eco-friendly: International E0 standard
Specification: H2350*W600*D450mm
Weight: 100Kg
Application: Suits for bigger rooms, for example, listening rooms, studio and home theater.

AQ1000SW integrates three sound optimization modes, the upper half of the front composite QRD medium and high frequency diffusion, the built-in Helmholtz resonator in the middle, and the lower labyrinth low frequency trap. Comb filtering and residual low frequency commonly found in rectangular spaces are the killer of sound quality. Conventional narrow-band diffusers and low-frequency traps are difficult to control. Bach's innovative acoustic array design and composite QRD diffusion break through everyone's concerns about QRD diffusion bandwidth, the built-in Helmholtz resonator captures the mid-low frequency margin in the most efficient way. The most unexpected thing is that its low-end labyrinth-type low-frequency trap phase guide runs through the back of the entire combination, and the 2.4-meter-long phase guide is realized. It reduces the consumption of ultra-low frequency headroom waves below 50Hz.

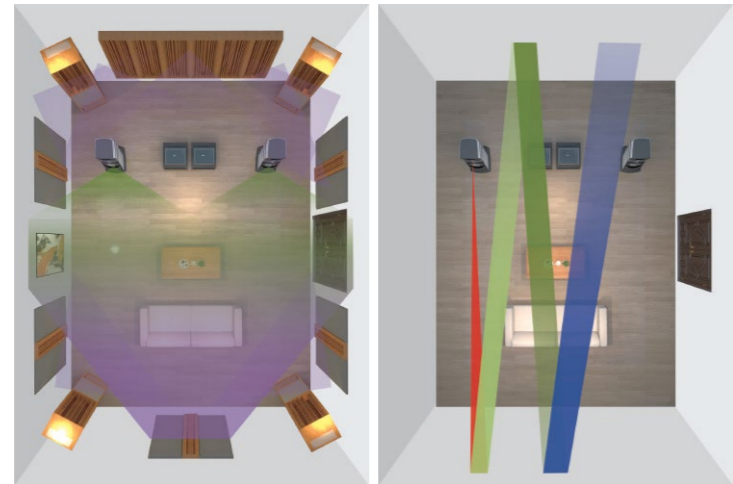
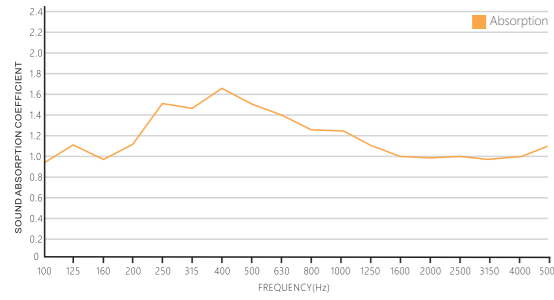

All the wrong kind sound reflection lean to exsessivereverberation and amplitude of vibration, which makesound location become difficult.

Our products can contro sound reflection and decrease standing wave in low frequencyvia acoustic treatment,improving acoustic enviromnt in smll space.



Name: Smartfuser
Mosdel: AQ1000M
Specification: H1200*W600*D200mm
Weight: ≤16.2kg/pcs.

Variable lath diffusion and cavity absorption design to effectively eliminate flutter echoes and standing waves. Diffusion angles can be adjusted as required by different applications e.g. recording rooms and home theaters, etc. sonichive "controllable diffuse reflection combination" is an innovative combination of diffusion and absorption to eliminate high frequency flutter echoes and effectively make use of the main reflected sound. The "controllable diffuse reflection combination" has an overall size of 600x1200mm, composed of 6 variable direction diffusion laths, which rotate to different angles to eliminate the high frequencies and create the required energy distribution. High density strong sound absorbing board is provided behind the reflection laths to effectively absorb 250Hz and eliminate the harmonic waves behind the oriented reflection board. It can be easily installed using just household tools in not more than 15 minutes. The elegant appearance with porous meshes and resin hardened edges makes it suitable for most architectural space designs. Install 3 or more units of Soundbox "controllable diffuse reflection combination" at the listening positions, and the spatial impression can be experienced immediately. In the meantime, the units absorb the negative reflections, standing waves and troublesome flutter echoes to tune the near wall main reflections for HIFI listening rooms home theaters and small audio studios

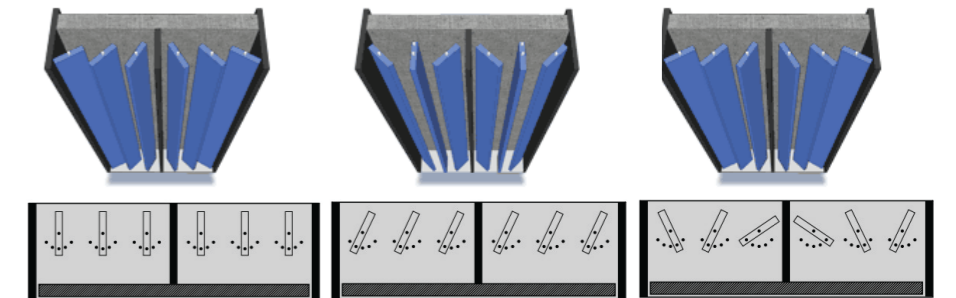
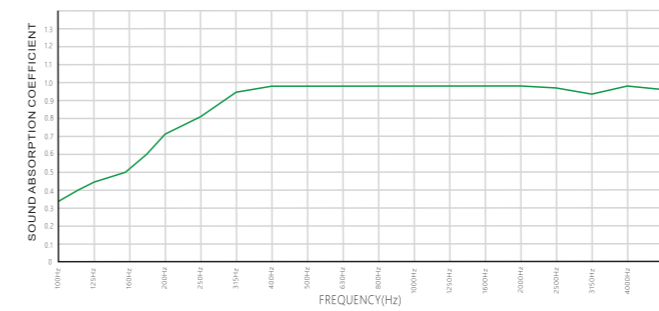

Vertical opening for sound absorption Inclined opening for reflection Left and right opening for diffusion

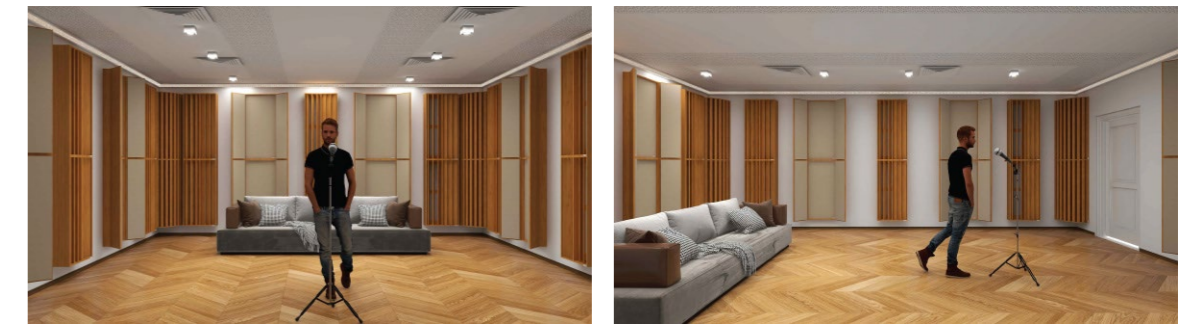
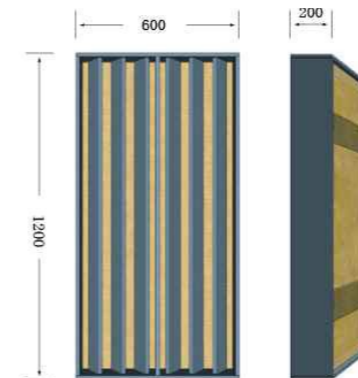



Name: Movable Acoustic Baffle
Mosdel: AQ1000H/HD
Structure Properties: A patented metal frame that is anti sound reflection & resonance and anti oxidation treated;
 Side A performs excellently in absorbing sound in all frequency.
 Side B--The MLS diffusing cloud is made by HIPS forming process.
Base Material: Ultramicropore glass fiber in different density. Green treatment without any formaldehyde emission.
Installation:
 1000H -- Standard fixing system with wheels; Hidden rectangle fixed groove
 1000HD --Standard holes for horizontal or vertical hanging
Finish: 1)Acoustical fabric for sound absorption;
 2)Diffusion side: PU Matte painting (Please refer to color chart for details)
Eco-Friendly: Up to international E0 standard
Flame retardation: Base material--Grade A
Size: AQ1000H 2100*800*200mm; AQ1000HD 2000*800*100mm
Weight: AQ1000H 28kg / AQ1000HD 15.5kg
Scope of Application:
 AQ1000H -- A semi-enveloped acoustic absorbing shell for portable stage
 AQ1000HD -- A hanging acoustic absorbing shell
Acoustic Properties: Movable acoustic baffle help to control long reverberation time, fluttering echo, parallel sound reflection and standing wave in medium frequency for churches, halls, multi-functional rooms, and studio. Meanwhile, it's a quick outdoor acoustic shell solution.



Name: Movable Acoustic Baffle
Mosdel: AQ150W
Structure Properties: Anti oxidation treatment, metal frame patented structure, AB full frequency strong sound absorption on both sides
Base Material: Ultra-micropore composite acoustic wool of different density, zero-emission and eco-friendly
Installation: AQ150W is equipped with a mobile pulley device as standard, and the frame is a hidden matrix fixed slot
Finish: Flocking flame retardant acoustic cloth
Eco-Friendly: Up to international E0 standard
Flame retardation: Base material--Grade A
Size: H1620*W800*D200mm
Weight: 15.6Kg
Scope of Application: Easily build movable sound absorption barrier
Acoustic Properties: The movable acoustic baffle can easily and effectively control the reverberation time, vibration echo, parallel plane reflection sound, medium and low frequency standing wave and other environmental sound defects in conference rooms, multi-function halls, offices and other spaces. It's quickly build and movable sound barrier structure, meets room acoustic requirements easily.

The two-sided absorbing design ensures very good sound absorption performance, and the ultra-micropore composite acoustic wool of different density and acoustic fabric finish enhances the absorbing coefficient. Equipped with universal mute wheel, the professional acoustic environment can be built and adjusted at any time. It can be assembled and disassembled in 5 minutes. It can be flexibly placed anywhere that decorate s the room well.

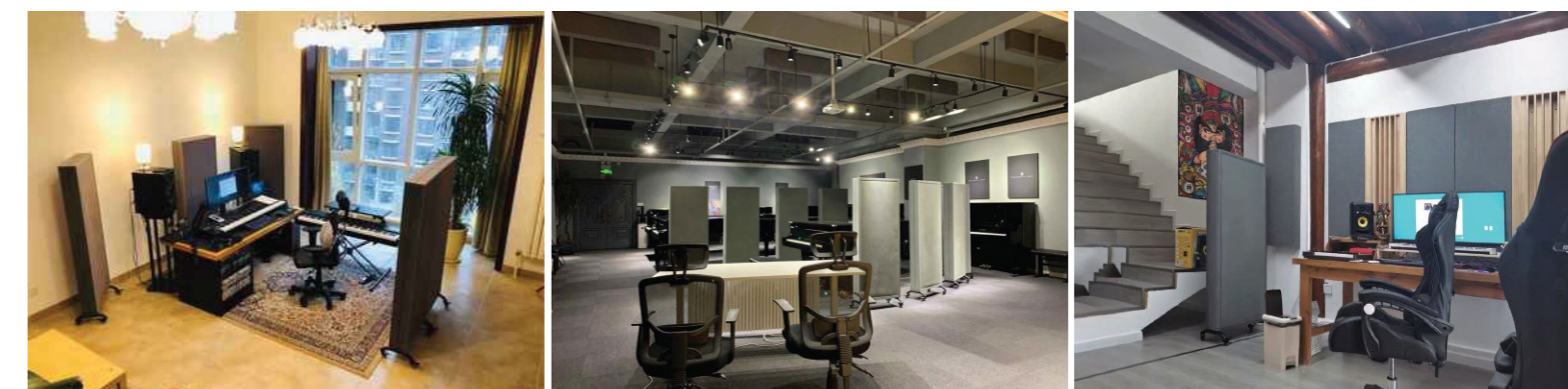
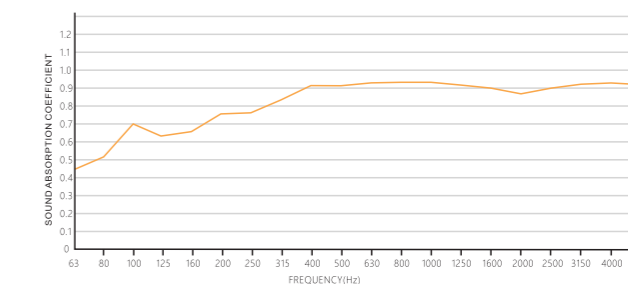
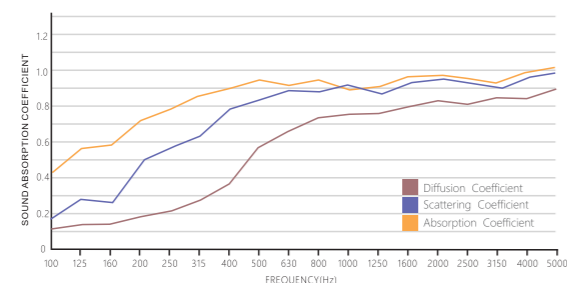

QRD 2D Diffuser Design Basis (Quadratic Residue)

Acoustic diffusion is an important part of building acoustics. Many calculations, for example, Sabine formula or Eyring formula calculation, are based on fully diffused acoustic fields. If an acoustic field is not fully diffused, the accuracy of acoustic calculations may be influenced. Therefore, it is an important part of building acoustics to make the sound fields diffuse evenly, beneficial for purification and improvement of the sound quality. The theories of acoustic field diffusion come from the quadratic residue diffusion theory proposed by Manfred Schroeder, a German physicist and acoustician in 1975. The results of diffusion using the method of quadratic residue sequence indicate that these cyclic sequences have the capability to distribute abundant harmonic waves in a balanced manner. In other words, the sound waves generated due to geometrics of the rooms or early reflected sound are re-distributed in the sense of time, and are released out smoothly. According to his research, the diffusion of sound waves greatly helps human ears with listening. In the quadratic residue diffusion theory, "quadratic" means the square root, and "residue" refers to the remainder of a natural number divided by a prime number (i.e. the remaining part of the number that cannot be fully divided other than 1 and the number itself). As the sound waves are made to be diffused more evenly, the quadratic residue diffusion boards have positive influence on the sound quality. The diffusion boards are composed of steps of different depths based on calculations as per the quadratic residue theory. The sound energy enters the steps and is then gradually released at different time. The result is that the peaks and valleys are smoother, forming a more balanced acoustic environment. The diffusion boards are used not only on ceilings but also on the side walls and the walls behind loudspeakers and behind the listening positions. The more the diffusion materials, the more can people feel the sense of space and the natural and graceful effect of high frequencies in the music places. The details of music can also be shown well; some minor dynamic changes normally hard to be perceived can be clearly shown. SonicHive two-dimensional diffuser (QRD) series are manufactured strictly in accordance with the quadratic residue diffusion board formula

QRD 2D Diffuser Design Basis (Quadratic Residue)

QRD diffuser is composed of a series of parallel sunk panels of different depths. When the sound wave is incident on a QRD at a horizontal position by 135°, it can reflect the sound out with equal strength by 30°-150°

QRD Diffuser Structure and Performance

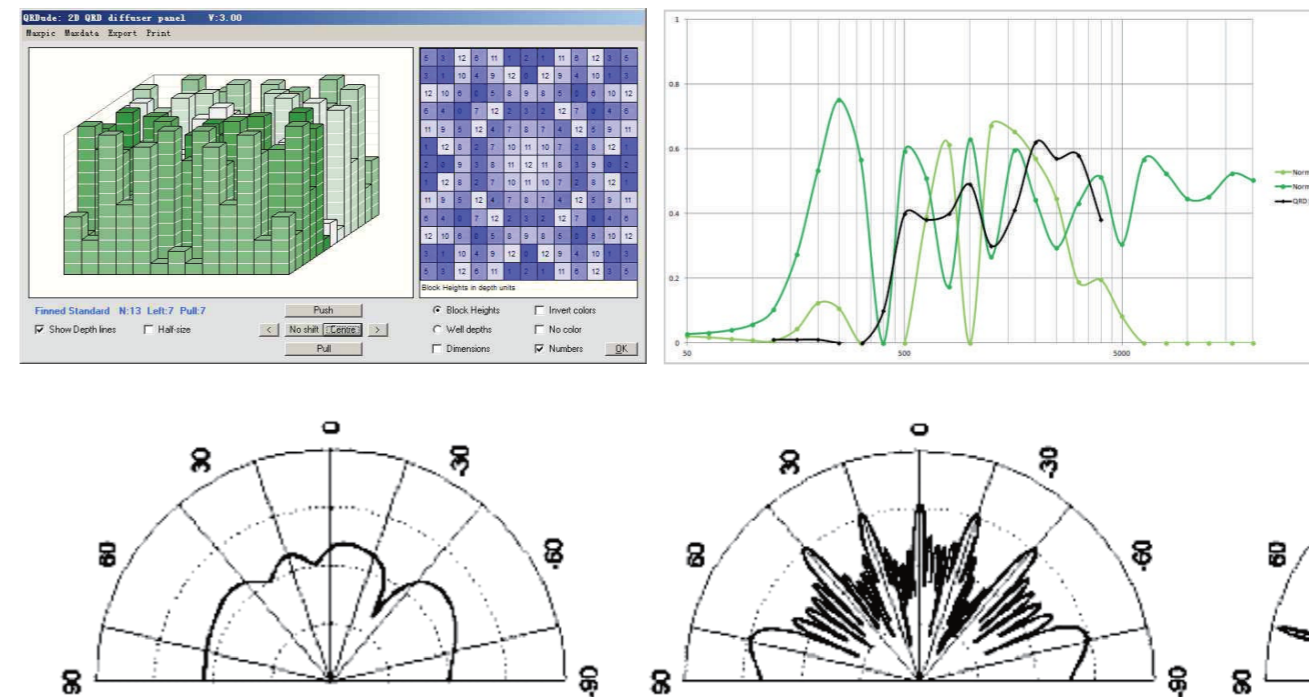
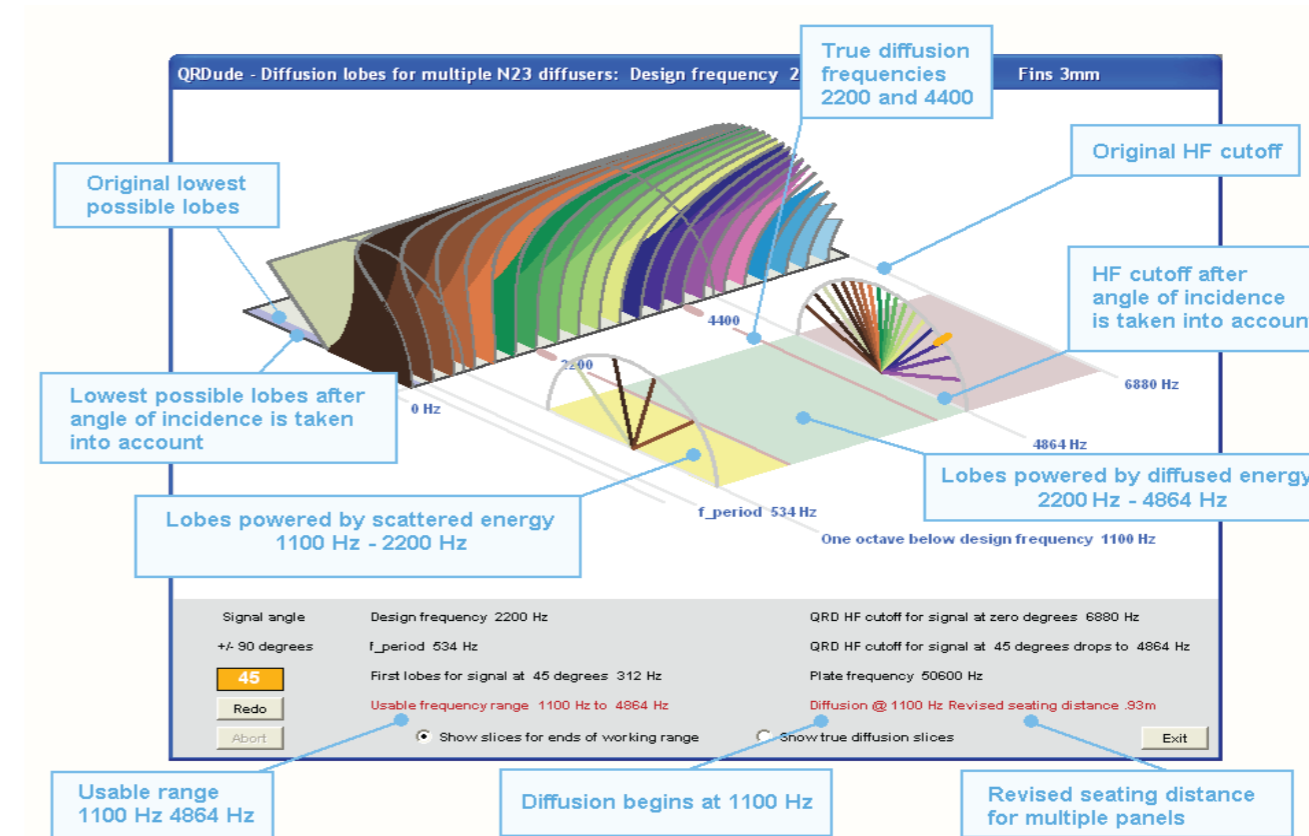
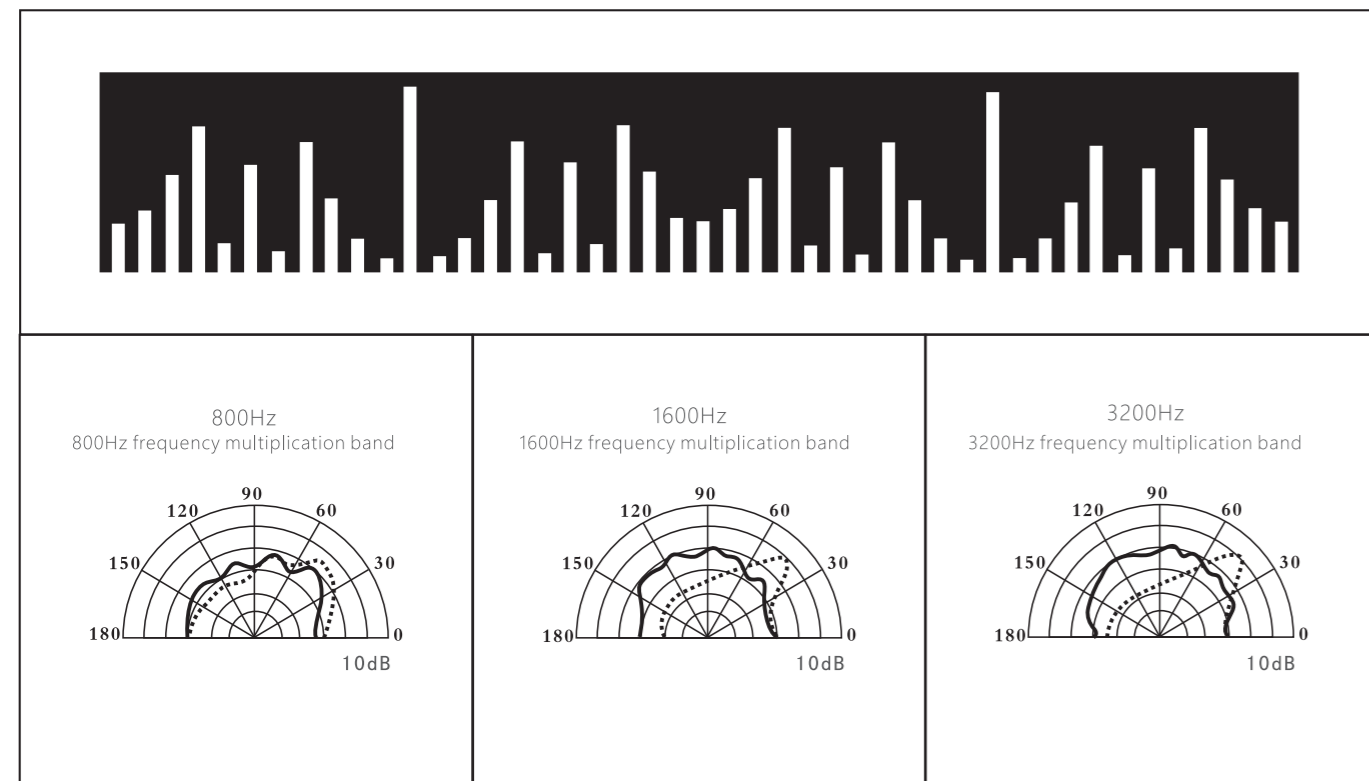



Name: Chessfuser
Mosdel: D64
Base material: rubber solid wood
Environmental protection: purely natural raw wood, natural and environment friendly
Finish: EO standard environmental friendly PU finish paint
Features: D64 solid wood diffuser is a located sequence grating based on QRD theoretic formula calculations. Its groove depth and width enable it to have uniform diffuse reflections for the incident sound from different angles and all the directions to make human voices more agreeable and high frequencies more gorgeous like in a large hall.
Diffusion frequency range: 430Hz-861Hz (maximum 2730Hz)
Scope of application: opera houses, music halls, places of leisure, private theaters, recording studios, HIFI listening rooms, etc. with high end indoor sound quality requirements for building acoustic decoration
Specification: H600*W600*D100mm
Weight: 11.6kg/pcs

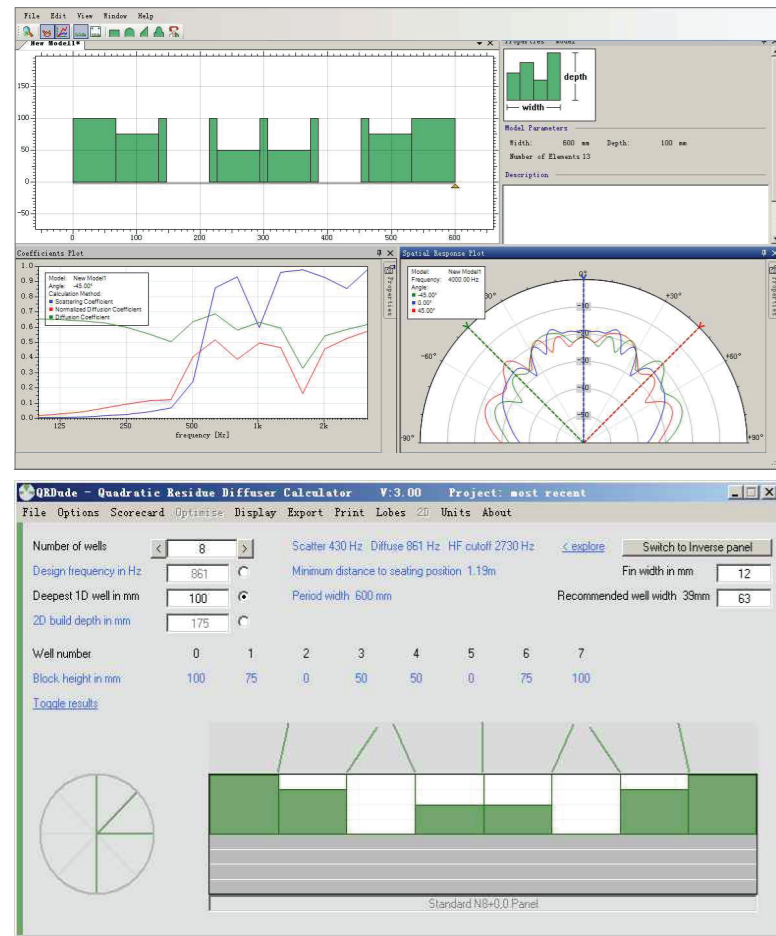

Name: Quadrifuser
Mosdel: D30S / D30
Base material: Rubber solid wood
Environmental protection: purely natural raw wood, natural and environment friendly
Finish: EO standard environmental friendly PU finish paint
Features: D30 solid wood diffuser can be used to diffuse the sound energy in a stereophonic manner, prevent echoes and standing waves to realize diffusion in all the directions, and improve the articulation of sound and the sense of space.
Scope of application: opera houses, music halls, private theaters, recording studios, HIFI listening rooms, etc. with high end indoor sound quality requirements for building acoustic decoration
Diffusion frequency range: 571Hz-1142Hz (maximum 5548Hz)
Specification: D30S H600*W600*D100mm
 D30 H1200/1800*W600*D100mm
Weight: D30S ≤11.8kg D30 ≤ 23.6/35.4kg

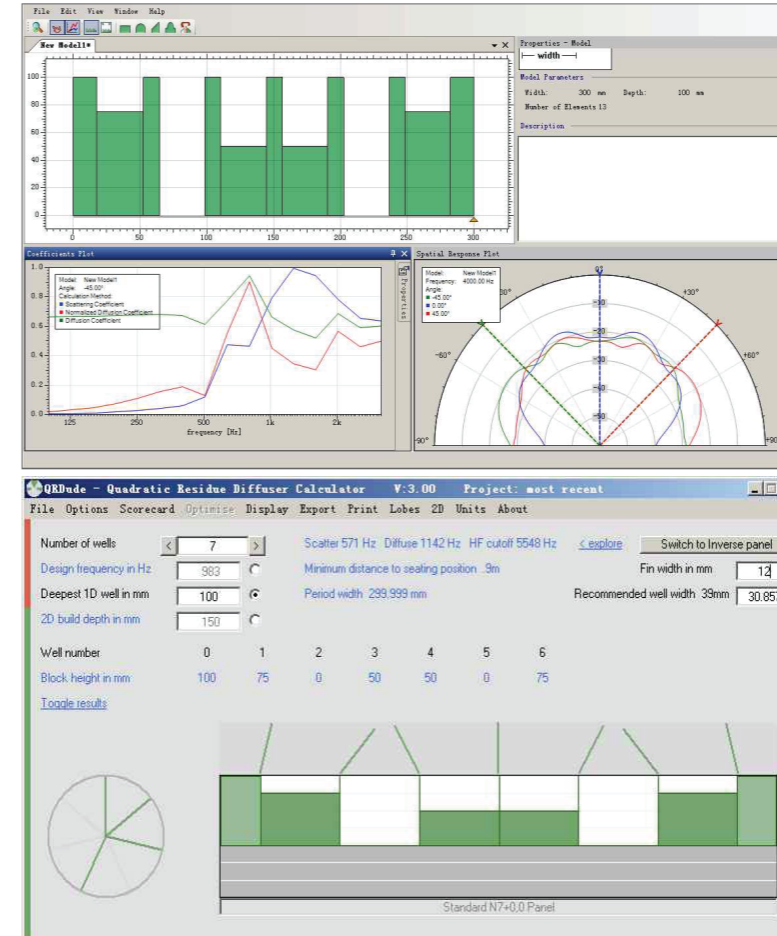



Name: Octofuser
Mosdel: N8
Base material: Rubber oak wood
Environmental protection: purely natural raw wood, natural and environment friendly
Finish: E0 standard environmental friendly PU finish paint
Features: N8 solid wood diffuser can be used to diffuse the sound energy, prevent echoes and standing waves to realize diffusion in all the directions, and improve the articulation of sound.
Diffusion frequency range: 491Hz-983Hz (maximum 2324Hz)
Scope of application: opera houses, music halls, places of leisure, private theaters, recording studios, HIFI listening rooms, etc. with high end indoor sound quality requirements for building acoustic decoration
Specification: H600*W600*D100mm
Weight: ≤11.5kg

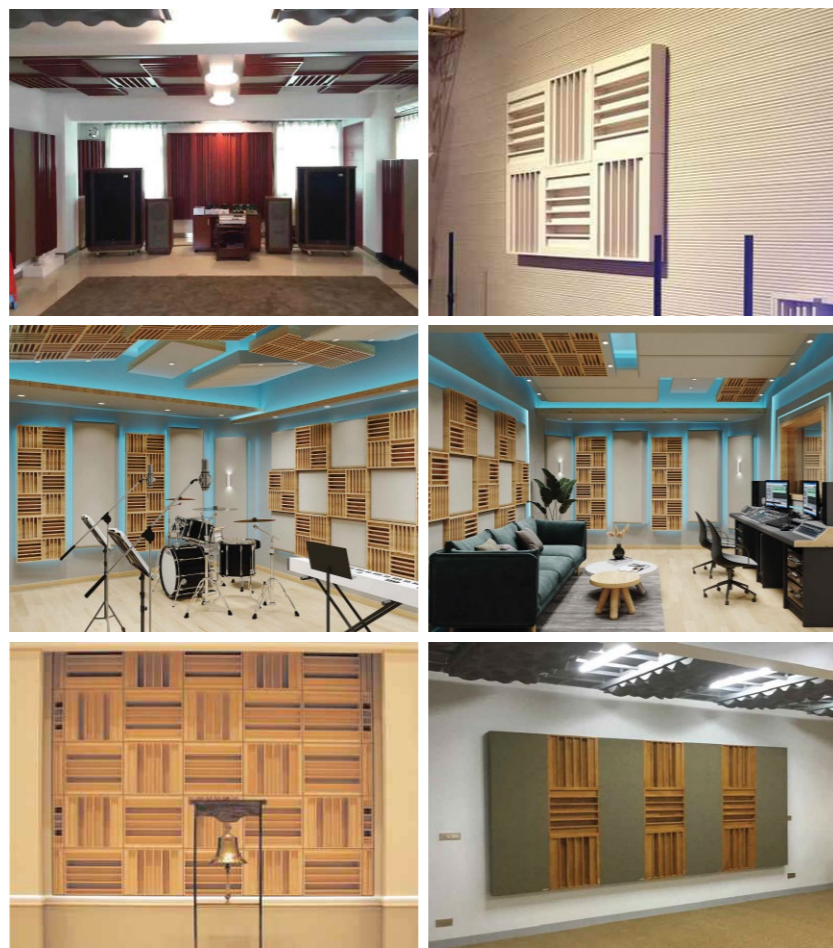
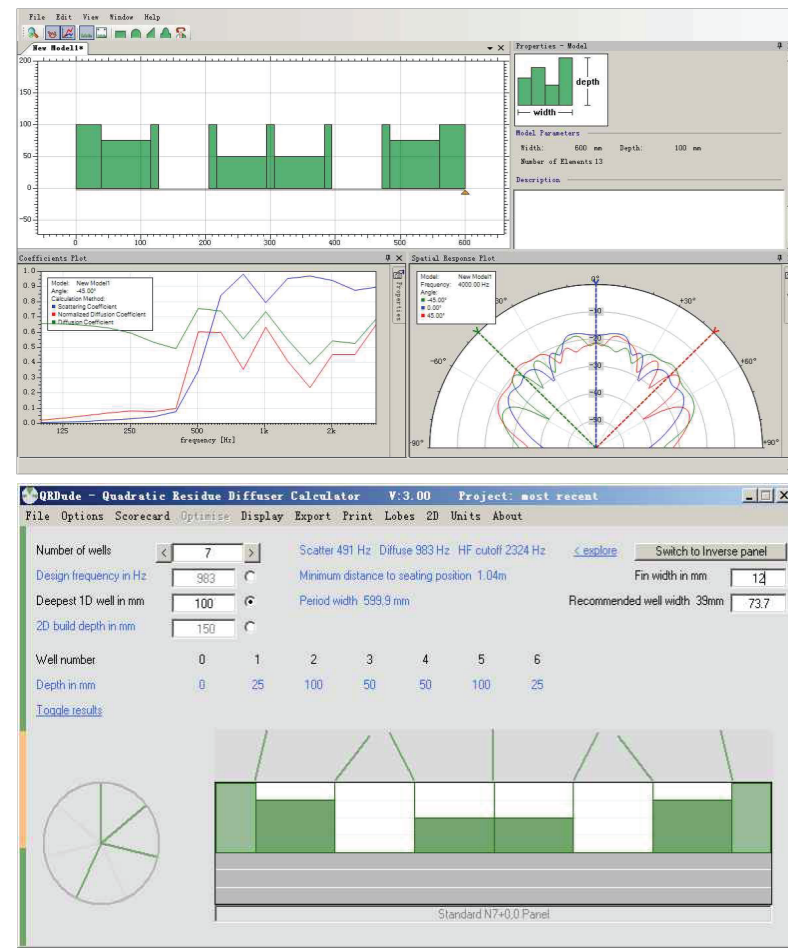

Name: Metafuser
Mosdel: N29
Base material: Rubber oak wood
Environmental protection: purely natural raw wood, natural and environment friendly
Finish: E0 standard environmental friendly PU finish paint
Features: N29 solid wood diffuser can be used to resume the sense of space of sound and improve the sound quality greatly. Its acoustic characteristics reach the requirements of national standards for materials of the same type. It is used along with solid wood sound absorbing boards with slotted holes to effectively improve the fullness, articulation and sense of stereophony of sound.
Diffusion frequency range: 524Hz-1049Hz (maximum 9555Hz)
Scope of application: opera houses, music halls, places of leisure, private theaters, HIFI listening rooms, etc. with high end indoor sound quality requirements for building acoustic decoration
Specification: H1200/1500/1800*W540*D158mm
Weight: H1200≤41.5kg / H1500≤51.8kg / H1800≤62.2kg

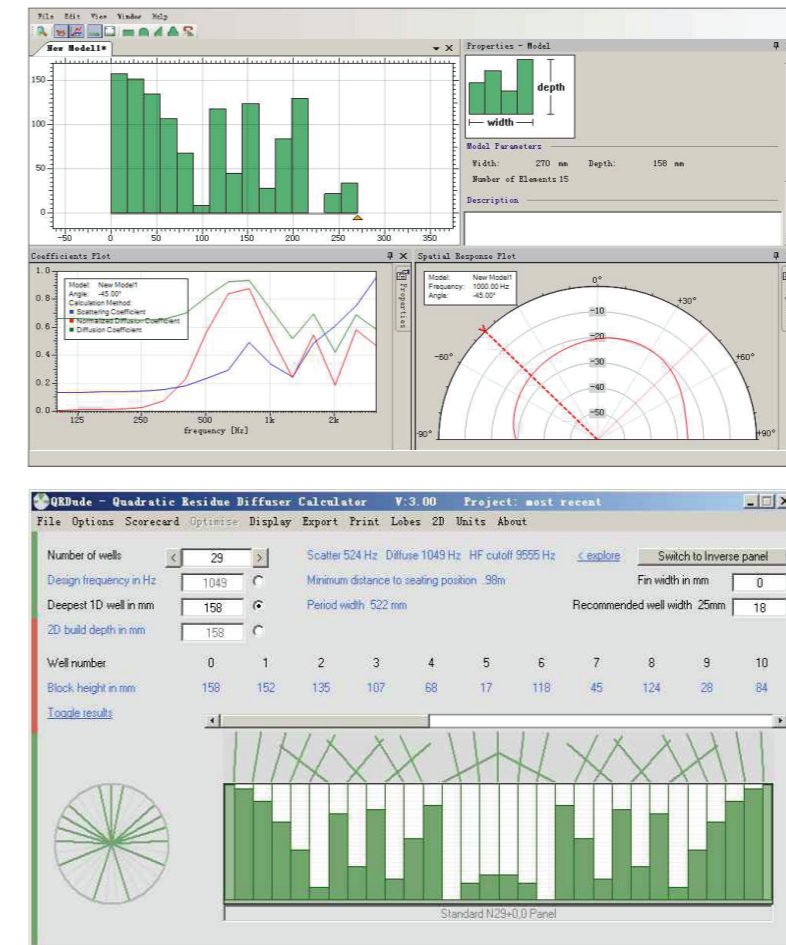

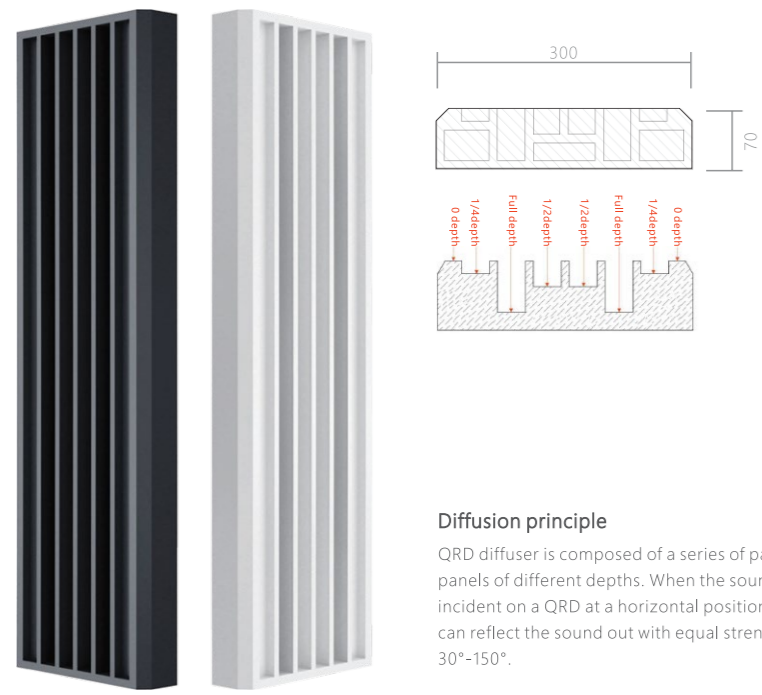

Name: FUSEASER
Mosdel: D80
Base material: rubber solid wood
Environmental protection: purely natural raw wood, natural and environment friendly
Finish: E0 standard environmental friendly PU finish paint
Main features: D80 has significant diffusion effect. On condition of not increasing the reverberation time, it can deal with the problem of sound dryness in small spaces effectively and improve the fullness, articulation and sense of stereophony.
Common specification: H1200/1500/1800*W300*D70mm
Weight: H1200≤10kg / H1500≤12.6kg / H1800≤15.1kg
Scope of application: Flush mounted at high grade places e.g. music halls, home theaters, HI-FI listening rooms and recording rooms, and places requiring improvement of sound quality and articulation

Diffusion principle
 QRD diffuser is composed of a series of parallel sunk panels of different depths. When the sound wave is incident on a QRD at a horizontal position by 135°, it can reflect the sound out with equal strength by 30°-150°.

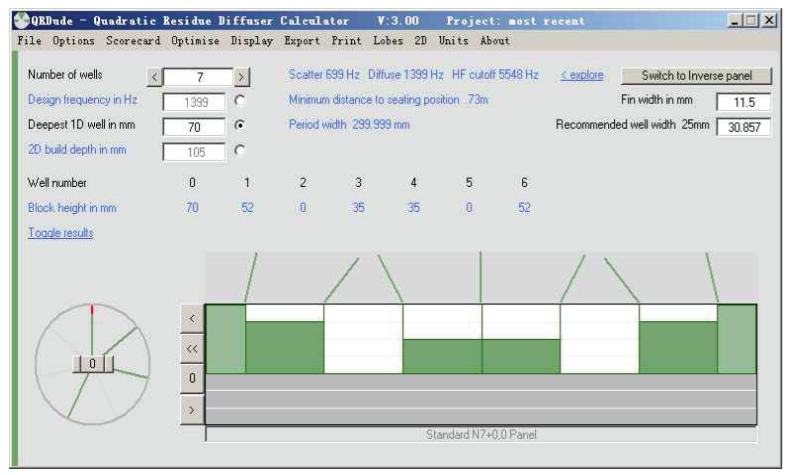
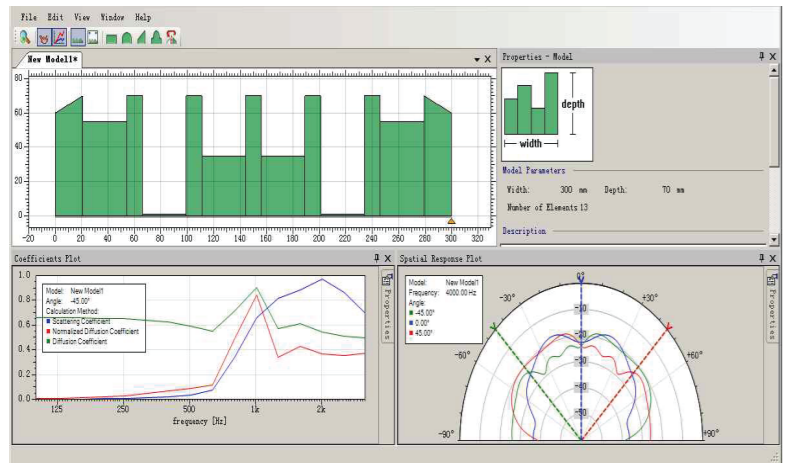

Name: TRAPFUSER
Mosdel: D80W
Base material: Rubber solid wood
Environmental protection: Purely natural raw wood, natural and environment friendly
Finish: E0 standard environmental friendly PU finish paint
Main features: D80W is an in-depth solution to the problem of standing waves in corners. As a combination of low frequency absorption and diffusion technologies, it not only solves the problem of sound confusion in corners, but also makes use of the corners to enhance the sound energy by at least 3dB, effectively improving the sound fullness, curve straightness, richness and sense of stereophony.
Common specification: H1200/1500/1800*W350*D350mm
Weight: H1200≤22.5kg / H1500≤28.1kg / H1800≤31.5kg
Scope of application: Wall mounted at places e.g. music halls, home theaters, HI-FI listening rooms and recording rooms, and places requiring improvement of sound quality and articulation
Diffusion principle:
 QRD diffuser is composed of a series of parallel sunk panels of different depths. When the sound wave is incident on a QRD at a horizontal position by 135°, it can reflect the sound out with equal strength by 30°-150°.

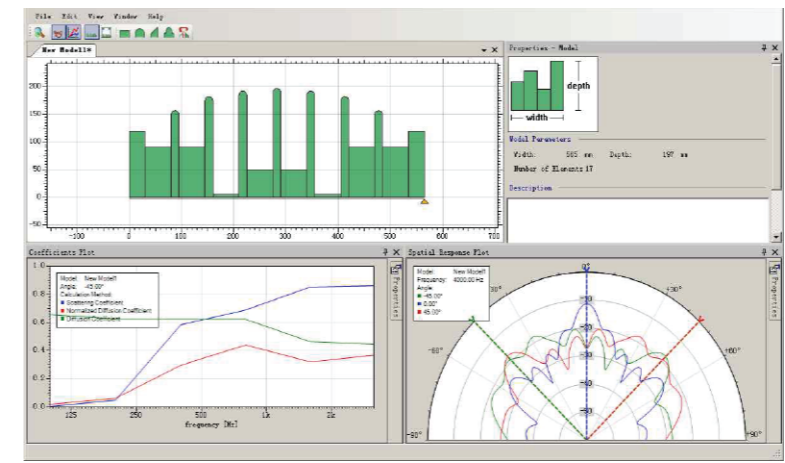
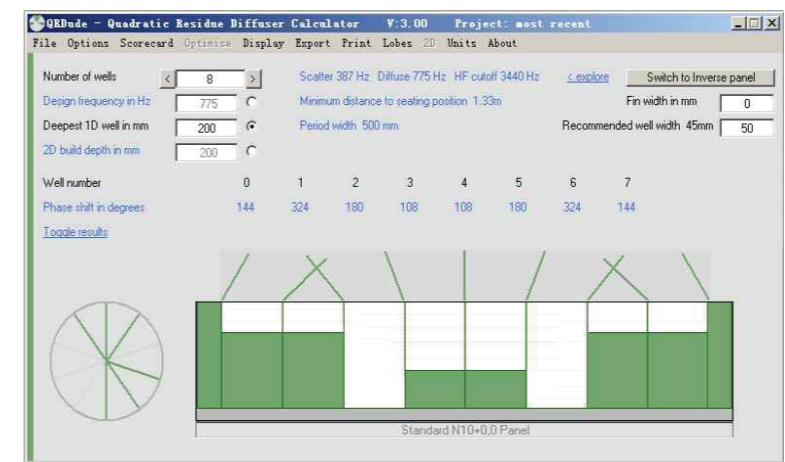



Name: TRIFUSER
Mosdel: D60
Base material: Rubber solid wood
Environmental protection: Purely natural raw wood, natural and environment friendly
Finish: E0 standard environmental friendly PU finish paint
Features: D60 solid wood diffuser is a located sequence grating based on QRD theoretic formula calculations. Its groove depth and width enable it to have uniform diffuse reflections for the incident sound from different angles and all the directions to make human voices more agreeable and high frequencies more gorgeous like in a large hall.
Scope of application: Opera houses, music halls, private theaters, recording studios, HIFI listening rooms, etc. with high end indoor sound quality requirements for building acoustic decoration
Diffusion frequency range: 491Hz-983Hz (maximum 2324Hz)
Specification: H1800*W600*D100mm
Weight: ≤29.6kg/pcs

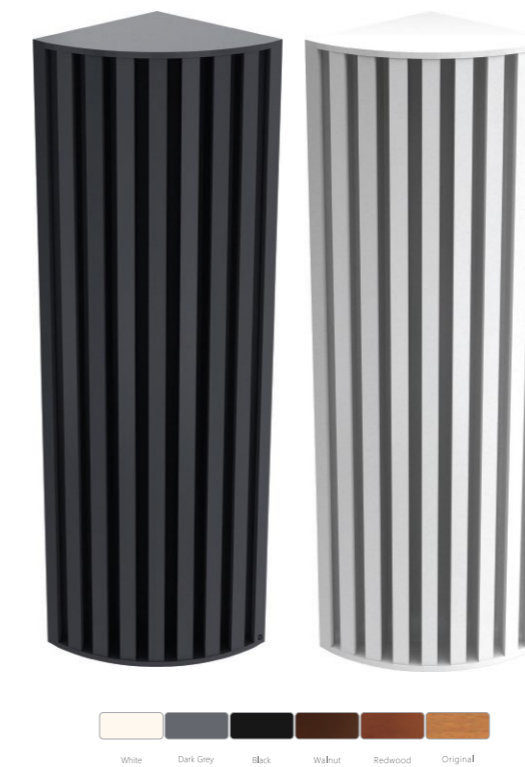
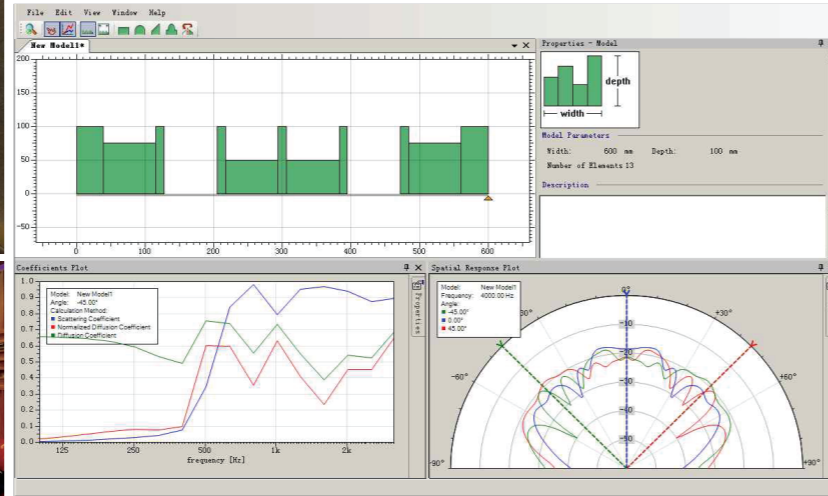
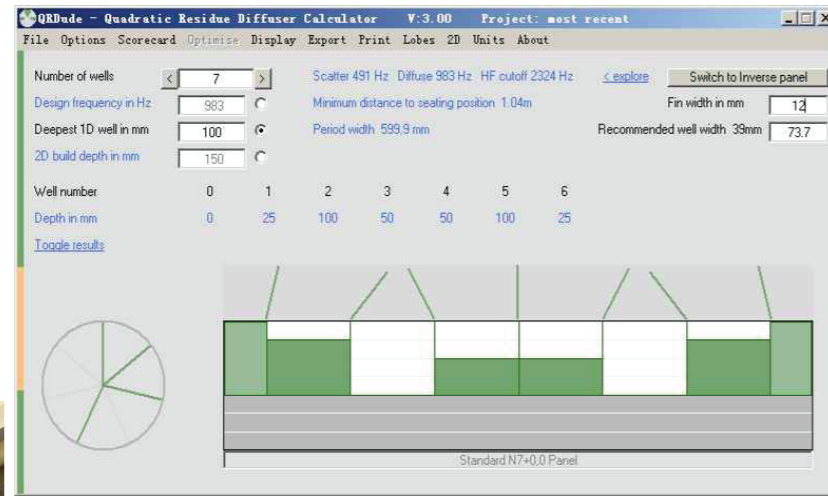

Name: TRAPFUSER
Mosdel: D60W
Base material: Rubber solid wood
Environmental protection: Purely natural raw wood, natural and environment friendly
Finish: E0 standard environmental friendly PU finish paint
Features: D60W can be used to absorb the sound energy, prevent echoes and standing waves to realize diffusion in all the directions, and improve the articulation of sound. The diffusion frequency has a range of (80Hz-250Hz), reaching 63Hz to the minimum.
Scope of application: Opera houses, music halls, places of leisure, private theaters, recording studios, HIFI listening rooms, etc. with high end indoor sound quality requirements for building acoustic decoration
Specification: H1800*W450*D450mm
Weight: 32kg/pcs

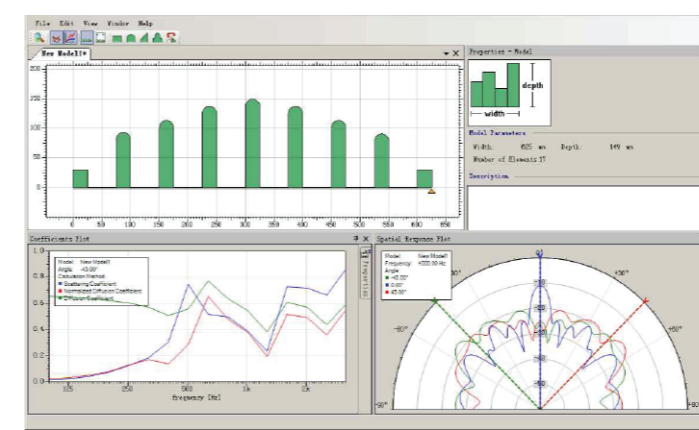
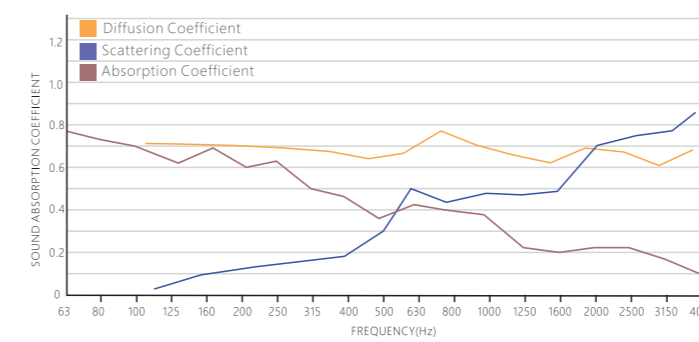

MLS 3D Diffuser

If only sound absorption measures are taken for building acoustic decoration works, the indoor space reverberation may totally disappear. Even if the sound sources are scattered at multiple points, the music or speeches still cannot reach some areas in the space, let alone the fullness of sound and sense of surrounding. The acoustic diffuser can diffuse the sound waves to create diffuse reflection of sound, help to reduce reverberation and improve the fullness of music.

In 1975, Schroeder, a German acoustician, proposed MLS diffuser based on a type of cyclic pseudo random sequence MLS in the number theory. MLS (maximum length sequence) is the largest length sequence in the binary system, commonly seen in error correcting codes and also often used in building acoustic measurement as the signal source of pseudo random noise. The MLS diffuser is composed of a series of concave and convex grooves with equal depth. The width of the grooves is determined by the MLS sequence, "1" corresponding to convex and "0" to concave. The design of MLS diffusion wall surfaces shall be based on mathematical calculations, and the results of the acoustic values as per the design scheme shall be measured in acoustic laboratories. In the audience halls of theaters, the acoustic diffusion wall surfaces are designed based on the MLS theory. The surfaces look irregular with concave and convex grooves, making the sound energy diffused and reflected as per the design requirement to ensure a uniform sound field in the halls to make the sound more agreeable.

sonichive three-dimensional diffuser is produced on the basis of the MLS theory as well as building acoustic design data for different functions, places and specifications, and actual application experience, after numerous tests on monomer and polymer forms, acoustic data tests and reliability tests. It is made of GRP macromolecule engineering materials currently widely used in the world.

sonichive three-dimensional diffuser can effectively and uniformly diffuse the sound waves to all the areas in the space stereophonically to create a performance hall level acoustic environment without the need for any complicated acoustic design or high cost.

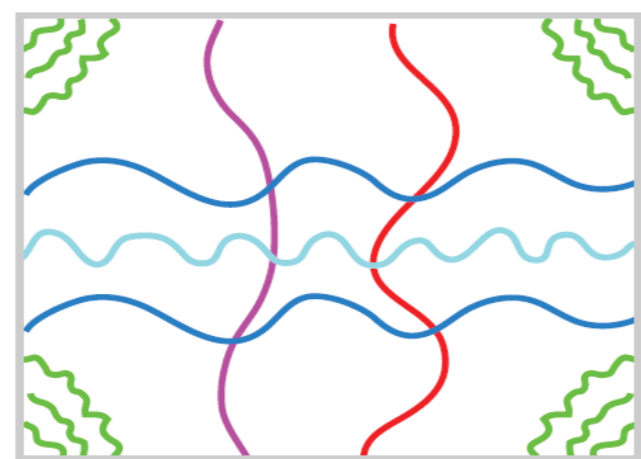
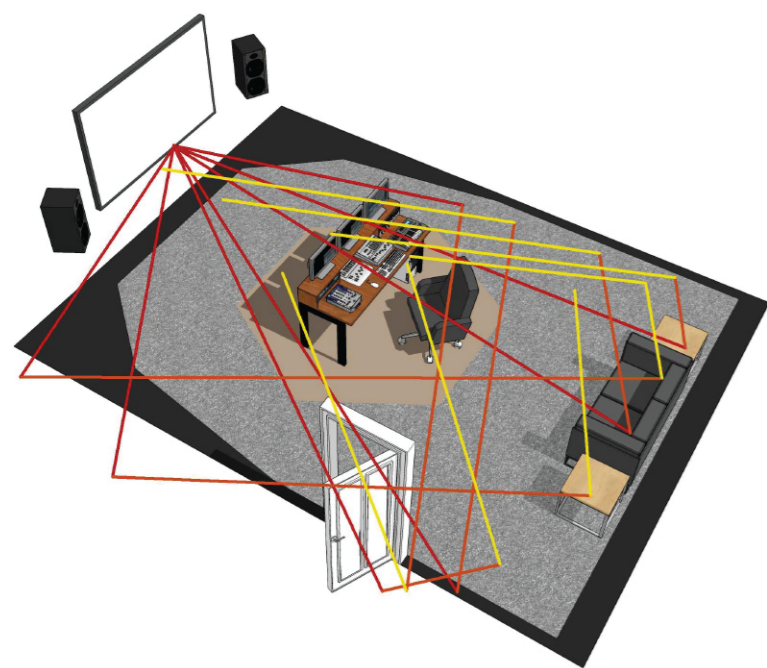

- Direct sound from sources
- Main reflections
- Secondary reflections
- Basic resonance wave
- Harmonic wave of resonance wave
- Echo effect from one side to the other
- Rapid echo effect from one side to the other
- Resonance waves in corners

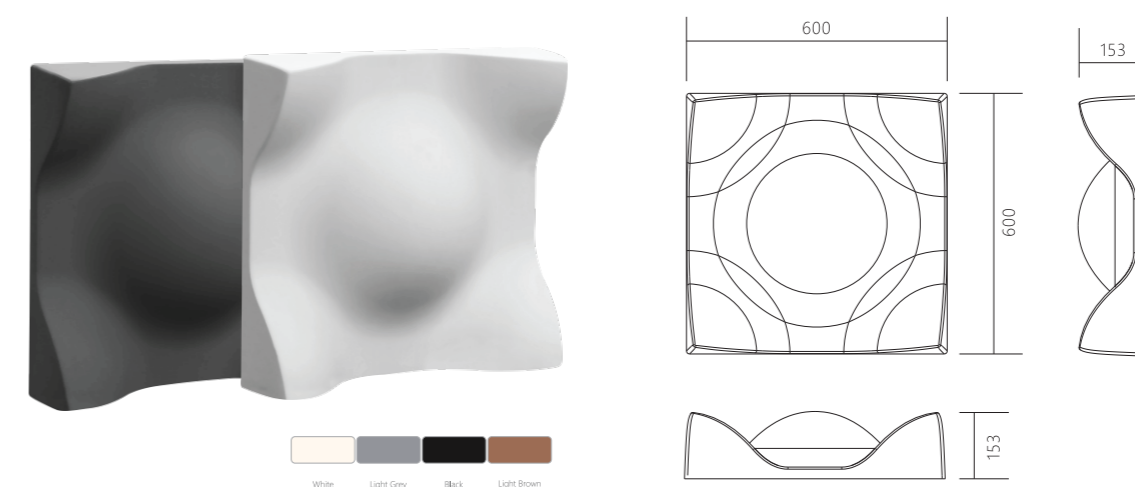

Name: Diffuser
Mosdel: PEAK SQ
Finish: PU paint, water-based paint, flocking
Diffusion indicator: 0.57/m² [> 100Hz - < 5KHz]
Size: H600×W600×D153mm
Environmental protection: 100% recyclable
Package: 2 pcs./box
Weight: 8kg/pcs

PEAKSQ convex diffuser redistributes the reflected sound energy. Though the re-orientation is not totally taken as the theoretical value for diffusion, the convex shape provides it good acoustic control performance to distribute sound more evenly. The 180°high efficiency radiation surfaces help to deal with the defect of acoustic shadow in the sound amplification system, which is difficult to be covered. Various SQ combinations are installed on the background walls of the sound amplification system to form horizontal diffusion surfaces to provide a gain of sound energy equivalent to 3dB. It can be used together with EQ tuning boards to create diffuse reflection surfaces. As Q5 provides high efficiency acoustic shaping performance and strong visual impact, it is ideal for the facade walls in the sound amplification system with accumulative direct sound energy, and suitable for music halls, pubs, night clubs, KTV rooms, instrument practicing rooms, etc.

Diffusion/Absorption Coefficient:

41	0.08	0.11	0.23	0.37	0.76	0.75	0.76	0.81	0.86	0.83	0.75	0.65	0.77	0.78	0.75	0.67	0.59	0.46	0.33	0.21	0.27	0.21	0.20	0.15	0.05
15	0.01	0.04	0.15	0.17	0.19	0.29	0.20	0.19	0.17	0.10	0.10	0.10	0.09	0.09	0.08	0.11	0.11	0.14	0.17	0.05	0.07	0.08	0.07	0.03	0.03

50 63 80 100 125 160 200 250 315 400 500 625 800 1k 1.25k 1.6k 2k 2.5k 3.15k 4k 5k 6.3k 8k 10k NNC

— ABSORPTION COEFFICIENT: Values in accordance with the standards EN 20554, ASTM C423 and EN 11654. Values (< 100Hz and > 9K) are Non-Standard Values.
 — DIFFUSION COEFFICIENT: These values were obtained by mathematical calculations and tests carried out in our laboratory.

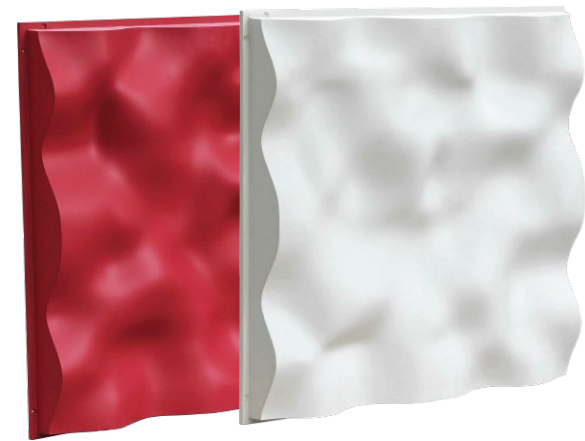

Name: Diffuser
Mosdel: CLOUD 2C / CLOUD 2C-LED
Diffusion indicator: 0.65/m² [>100Hz-<5KH]
Size: 600*600*90mm
Environmental protection: 100% recyclable
Package: 3pcs./box
Weight: CLOUD 2D: 5.6kg/pcs.
 CLOUD 2D-LED: 6.2kg/pcs.

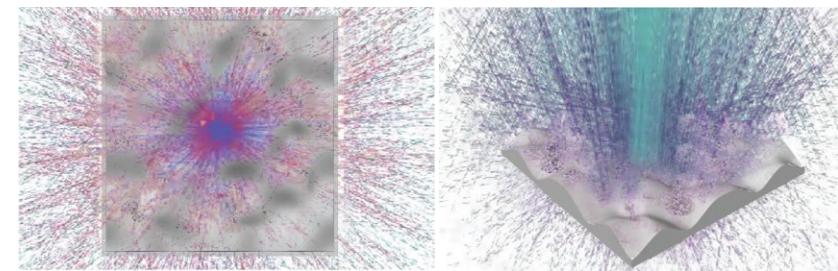
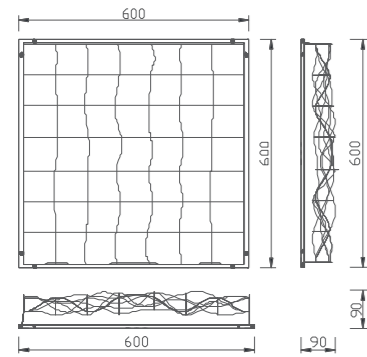

■ Diffusion / ■ Absorption Coefficient

45	0.01	0.01	0.02	0.09	0.19	0.19	0.20	0.29	0.32	0.43	0.49	0.51	0.53	0.60	0.61	0.64	0.52	0.65	0.82	0.80	0.83	0.72	0.72	0.63	0.65
63	0.07	0.11	0.46	0.19	0.33	0.33	0.40	0.42	0.44	0.41	0.38	0.39	0.35	0.35	0.33	0.32	0.23	0.26	0.27	0.22	0.20	0.19	0.15	0.18	0.39

— ABSORPTION COEFFICIENT: Values in accordance with the standards EN 20054, ASTM C423 and EN 11654.
 — DIFFUSION COEFFICIENT: These values were obtained by mathematical calculations and tests carried out in our laboratory.
 ■ Values (<100Hz and > 5K) are Non Standard Values.

Cloufuser adopts a single asymmetrical base model with aperiodicity bass-relief wave form shape. The center uniformity design provides a natural drop through high and low frequencies. The square shape provides the combination of two cloufusers and becomes a symmetry reflector that keeps integrality and continuity of diffusion, which centers diffusion frequency on 1K. Cloufuser uses GRP material molding, a level fire resistance, E0 environmental protection, color selection, and optional LED light star sky effect. Cloufuser internal cavity combined with the ceiling cavity structure can become a difference thickness lower frequency absorber. CLOUD2C is suitable for Home Theater, Auditorium, big size Office Room, and Multifunction Room. Its acoustic feature and nice looking can effectively improve the sound space and provide a nice sound diffusion system. There are low power of 5W LEDs hidden in CLOUD2C-LED, effectively making a perfect integrity of imagination and sound. It's an easy acoustic system for home theater, Club and KTV that combines acoustics and aesthetics.

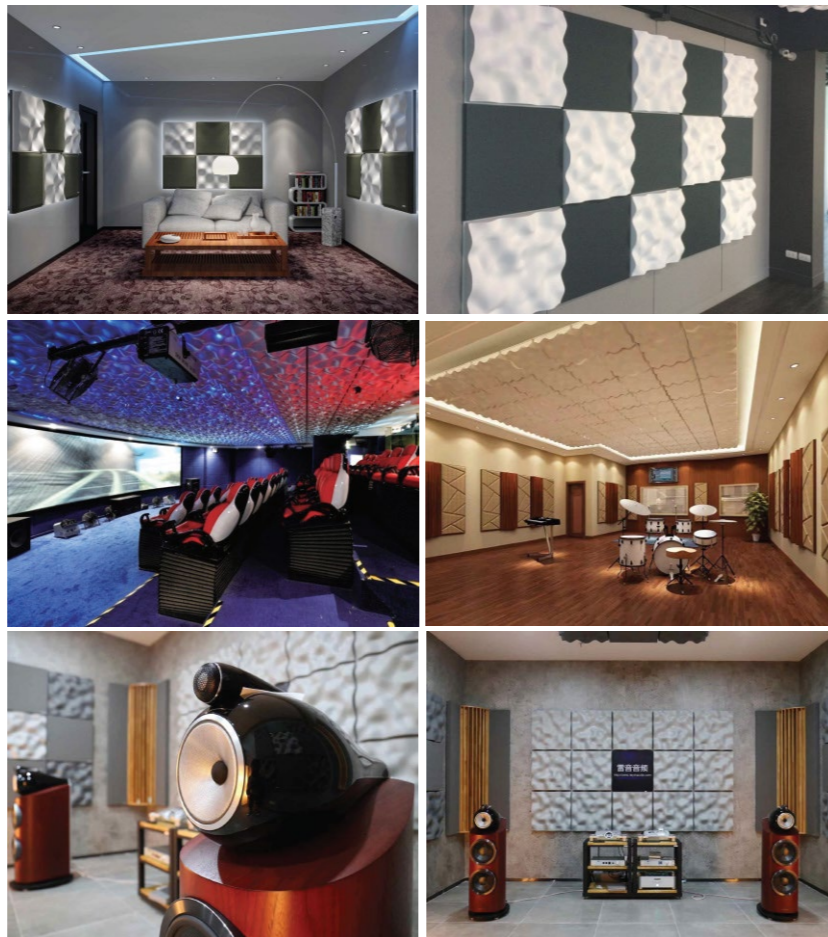

Cloufuser Installation

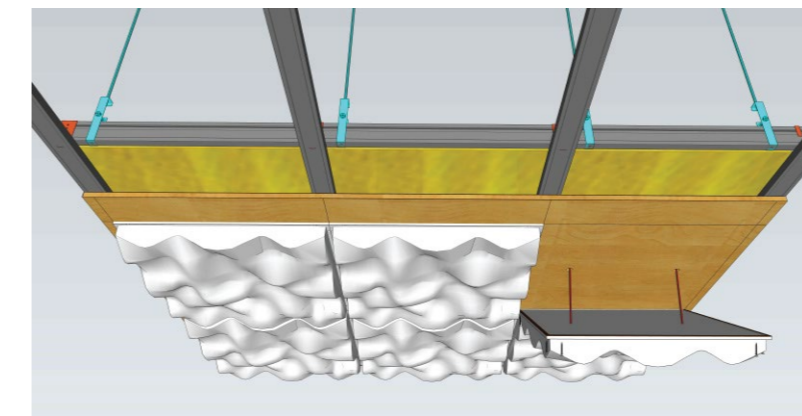

Installation Method 1:
 15mm thickness plywood on the base, and draft a size 600*600mm frame, filling 48kg/m³ rock wool backside cavity, with EVA damping rubber on the bottom and 8pcs self-tapping screw to fix it for each panel, if with LED light, please do the 12 lower voltage wire at first. Base plywood better for lower frequency below 125Hz diffuse, which apply for the listening room and small size private home theater.

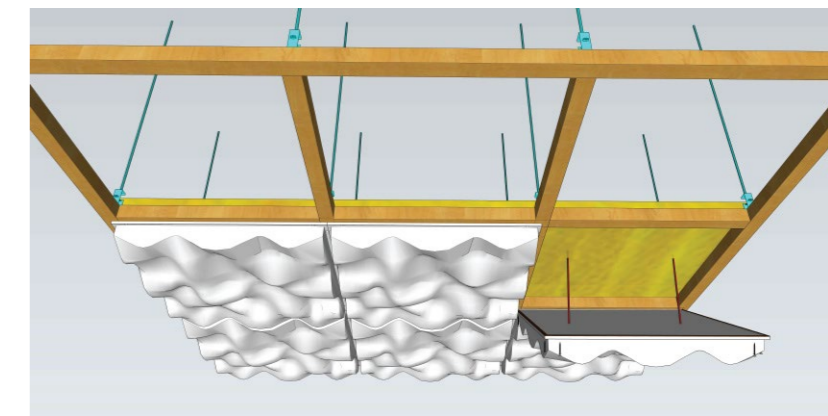

Installation Method 2:
 Installed on the size more than 40*60mm wood frame, keeping 600*600mm distance between keel's center, filling 48kg/m³ rock wool backside cavity, with EVA damping rubber on the bottom and 8pcs self-tapping screw to fix it for each panel from center to all round. If with LED light, please do the 12 lower voltage wire at first. Wooden frame cavity better theater and bars bigger space low frequency and standing wave absorption as it helps to absorb frequency below 125Hz.

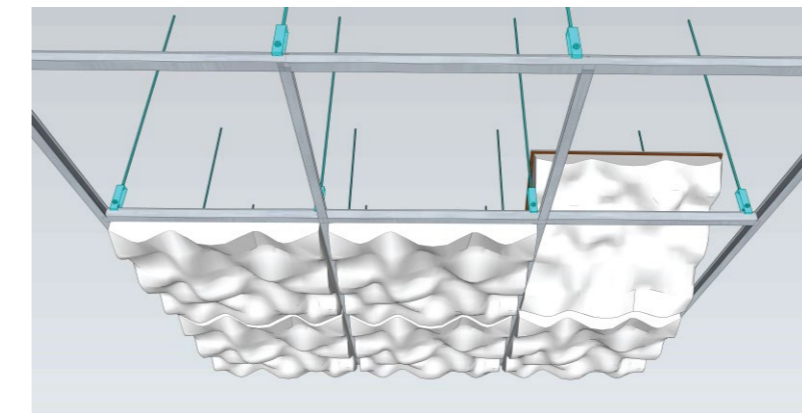

Installation Method 3: T-bar installation
 Keeping is 600*600mm distance between keel's center, with EVA damping rubber on the bottom install it from the center area to all round. If with LED light, please do the 12 lower voltage wire at first. As low cost of T-keels installation, it fits acoustic space demanding high frequency diffusion and low frequency absorption, for example, public places like churches.

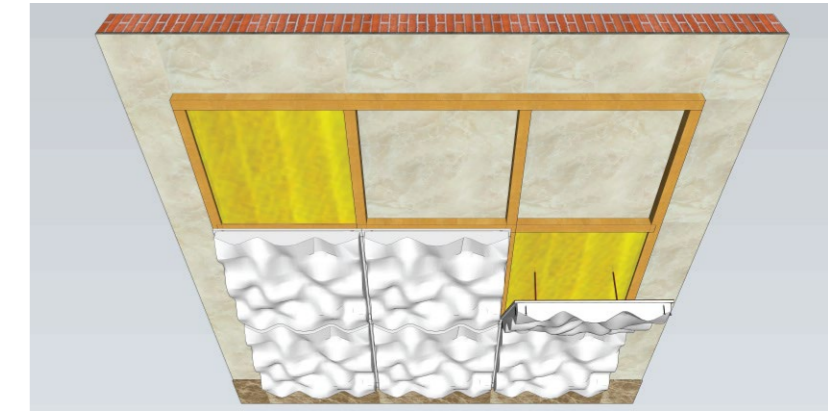

Installation Method 4: As for wood frame for wall, it is supposed to adopt wooden one which is bigger than 40X60 mm, keeping 600*600mm distance between keel's center, filling 48kg/m³ rock wool backside cavity, with EVA damping rubber on the bottom and 8pcs self-tapping screw to fix it for each panel from center to all round. If with LED light, please do the 12 lower voltage wire at first. Wooden frame in such structure better bars and multifunctional halls low frequency and standing wave absorption as it helps to absorb frequency below 250Hz.

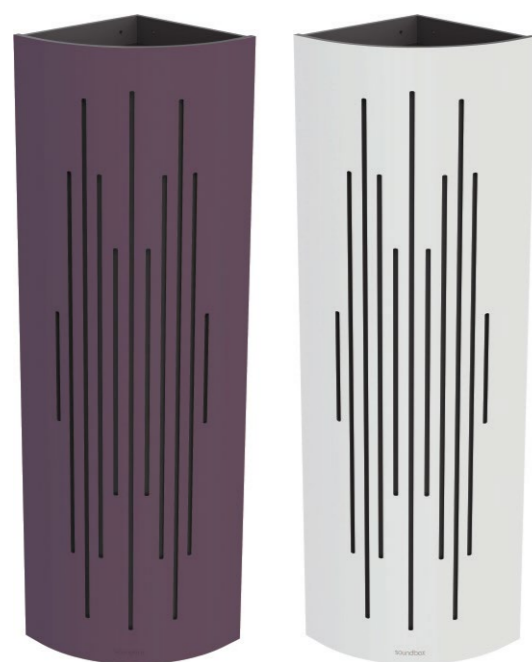

Name: ARC diffuser (bass trap)
Mosdel: ARC 300W
Base Material: Carbon polymer composite material
Finishing: Hot coated PP finishing
Environmental rating: E0
Acoustic Properties: A 90°Curve diffusing surface using hot mold without glue with 20% different slot for absorbing broadband frequency. There's a triangle low frequency absorbing cavity inside, filled with green acoustic material to absorb standing waves at 250Hz effectively. At the same time, this cavity scatters the beneficial sound energy gathered on the corner. That is a way to minimize the consumption of sound energy from acoustic system.
Application: multifunctional hall, private cinema, recording studio, HIFI room and other high end space which needs to do acoustic decoration.
Scope of Application: Concert, Multi-functional hall, Private cinema, Studio and HIFI room and other high end interior acoustic decoration
Size: H1200/1500/1800 * W300 * D300mm
Weight: H1200≤11 5kg / H1500≤14 4kg / H1200≤17kg

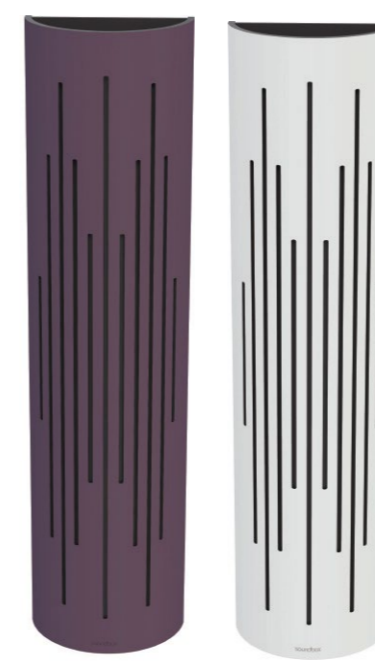
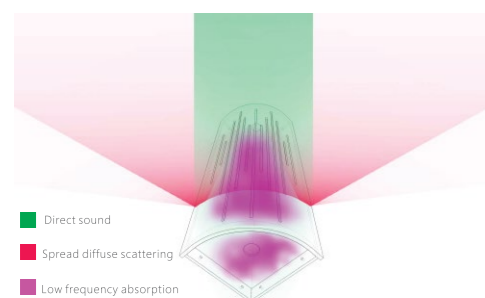
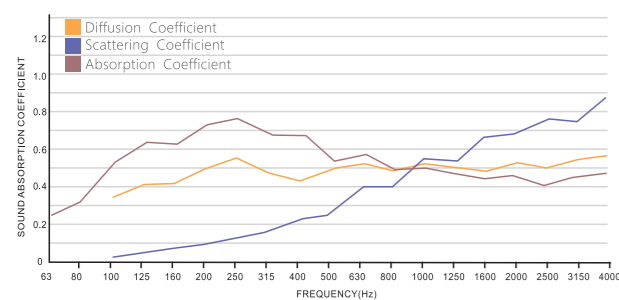

Name: ARC diffuser
Mosdel: ARC 300
Base Material: carbon polymer composite material
Finishing: hot coated PP finishing
Environmental rating: E0
Feature: A 180°Curve diffusing surface using hot mold without glue with 20% different slot for absorbing broadband frequency. There's unbalanced low frequency absorbing cavity inside, filled with green acoustic material to absorb margin sound below 350Hz effectively. The sound reflected will be fully diffused in certain directions. In this way, we do not only save sound energy consumption, but also obtain a relatively balanced acoustic environment.
Application: multifunctional hall, private cinema, recording studio, HIFI room and other high end space which needs to do acoustic decoration.
Size: H1800/1500/1200/600 * W300 * D150mm
Weight: H1800≤14kg / H1500≤11.7Kg / H1200≤9.23Kg / H600≤5Kg

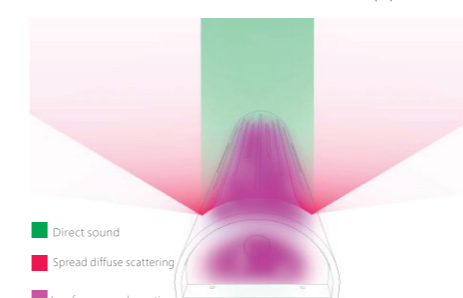
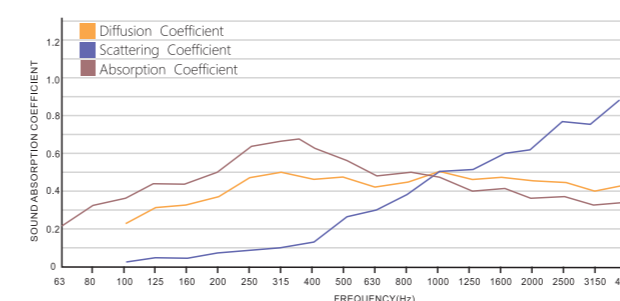



Name: Diffuser
Mosdel: WAVE 600
Base Material: Carbon-plastic composite
Finish: Heating compound pp veneer
Environmental protection: E0
Features: Three wave-shaped diffusion with superimposed double-range bands. It has the function of sound absorption with 20% asymmetric design. It built-in low-frequency absorption cavities with three unequal volumes. To absorbing 550-250Hz low frequency, it landfilled with eco-friendly acoustic material. The MLS diffuser horizontally scatters and balances the reflected sound, so as to get a more uniform sound environment without losing sound energy.
Scope of Application: Sound quality decoration in high-end indoor spaces such as concert halls, multi-function halls, private theaters, recording studios, HIFI listening rooms, etc.
Size: H1800/1500/1200/600 * W600 * D160mm
Weight: H1800≤28Kg H1500≤23kg H1200≤19kg H600≤9 5Kg

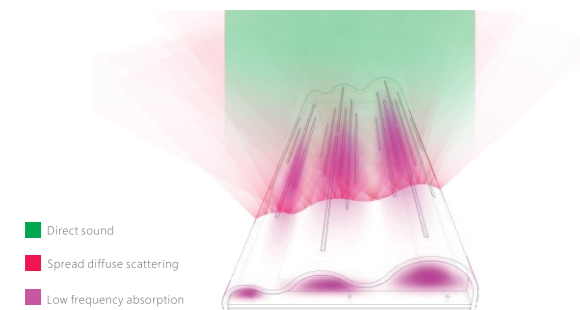
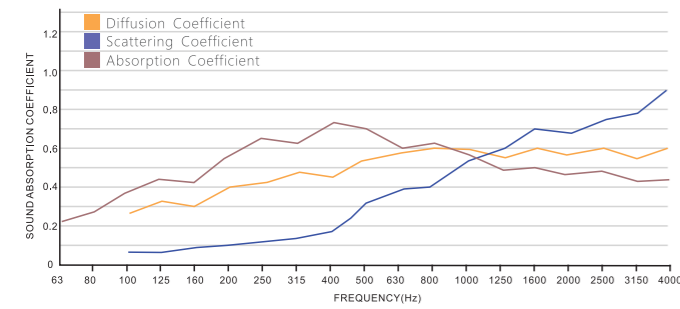

Name: Diffuser
Mosdel: PEAK 2000A / D (A-sound absorption & diffuser/D-diffuser only)
Substrate: Carbon-plastic composite
Finish: Heating compound pp veneer
Environmental protection: E0
Features: Three wave-shaped diffusion with superimposed double-range bands. It has the function of sound absorption with 20% asymmetric design. It built-in low-frequency absorption cavities with three unequal volumes. To absorbing 550-250Hz low frequency, it landfilled with eco-friendly acoustic material. The MLS diffuser horizontally scatters and balances the reflected sound, so as to get a more uniform sound environment without losing sound energy.
Scope of Application: Sound quality decoration in high-end indoor spaces such as concert halls, multi-function halls, private theaters, recording studios, HIFI listening rooms, etc.
Size: PEAK2000A H2000 * W800/400 * D200mm
 PEAK2000D H2000 * W800/400 * D200mm
Weight: PEAK2000A W800≤42.5kg / W400≤32kg
 PEAK2000D W800≤43.3kg / W400≤22kg

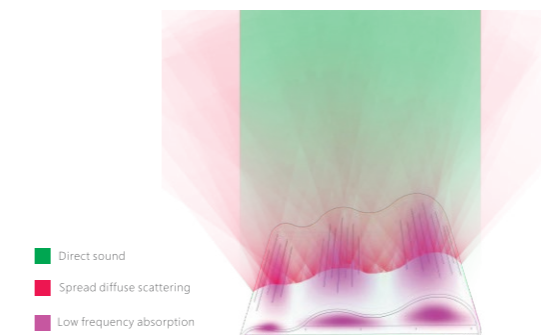
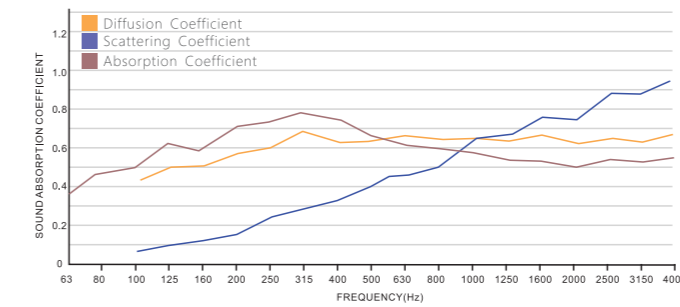

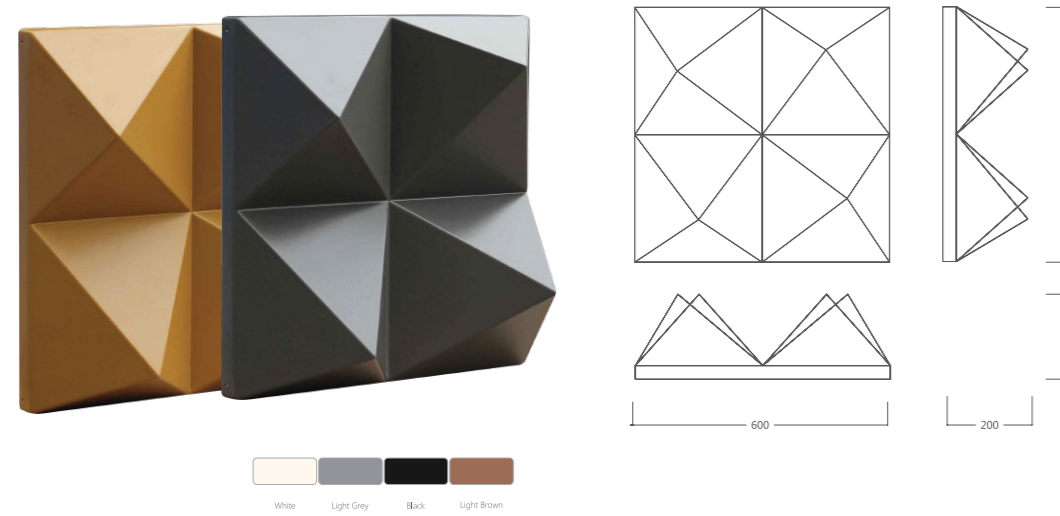

Name: Diffuser
Model: PYRAMID 4Q
Finish: PU paint, water-based paint, flocking
Diffusion indicator: 0.57/m² [> 100Hz - < 5KHz]
Specification: H600*W600*D200mm
Environmental protection: 100% recyclable
Material: HIPS
Package: 2 pcs./box
Weight: 4kg/pcs.

PYRAMID4Q conical surface diffuser follows the design of 1/4 unsymmetrical reflection phases. When the sound waves get in contact with the smooth PYRAMID4Q conical surface diffuser, the waves will be reflected in the planned directions instead of in all the same direction to effectively reduce the standing waves and sound flutter on the wall surfaces. Such a cavity under a non equilateral structure is able to absorb low frequency via diaphragm effect which effectively improve sound clearance. After the sound waves are reflected by the surfaces of PYRAMID4Q conical surface diffuser, the sound energy will be reflected in different directions with varied phase differences. Such irregular reflected sound with equal energy will provide a sense of space to the human ears, and increase the "brightness" of sound for diffusion of high and medium frequencies. The sound energy is reflected evenly in square double angles.

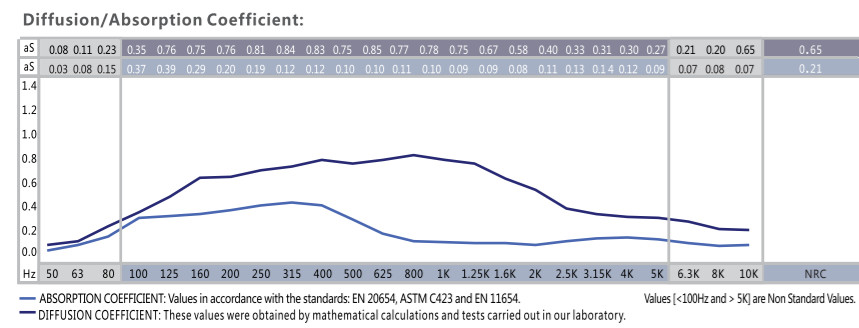
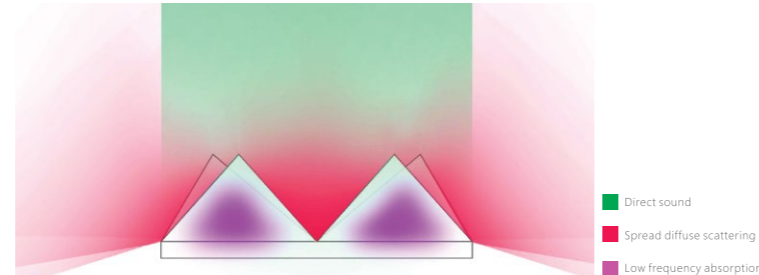

Product Parameters

Appearance	Name	Model	Unit load(KG)	Color	Surface size	Applicable
Φ4	Rings	Φ4	≤30	Galvanizing primary color	Φ4*10mm	EQ3 Walleasear
Φ6/Φ8	Rings	Φ6	≤80	Galvanizing primary color	Φ6*10mm	Walleasear
M6/M7	Hanger	M6	≤60	Galvanizing primary color	60*25mm	
Φ1/Φ2	Steel wire	Φ1	≤30	Black coated steel wire	Φ1*500mm	Wooden acoustic items
	Rings	Φ8	≤120	Galvanizing primary color	Φ8*12mm	
	Hanger	M7	≤80	Galvanizing primary color	70*30mm	
T1	Steel wire	Φ2	≤75	Black coated steel wire	Φ2*500mm	Customized fabric acoustic items
	Ceiling hanging tray	T1	≤10	Black	Φ 120 hanging tray, 3 steel wires, 2 sets of screws	
T2	Ceiling hanging tray	T2	≤12	Black	Φ 150 hanging tray, 4 steel wires, 2 sets of screws	Matrix fabric acoustic items
80A 80B 50A 50B	Velcro	80A/80B	≤5	Black	Φ80	Walleasear Acoustic Panel
	Velcro	50A/50B	≤3	Black	Φ50	Walleasear Acoustic Panel
WS40	Roller	WS40	≤30	Black	Φ40	AQ1000S Acoustic Baffle